



G4 CGC Series Digital Coffee Brewing System



READ AND SAVE THESE INSTRUCTIONS

NOTICE TO INSTALLER: Please leave this booklet with the machine.

Key Features/Specifications/System Requirements.....FS19

Important Safeguards.....IS2

Important Safeguards (EC).....IS15

Installation Instructions (General).....II2

Installation Instructions (Leveling, Water Supply, Electrical).....II13

Operating InstructionsOI16

Cleaning Instructions (Brewer)CI1

Cleaning Instructions (Brew Basket)CI10

Programming GuidePG34

Rough-In Drawing.....RD25

Illustrated Parts/Recommended Parts (Main Chassis, Top Wrap).....IP29

Illustrated Parts/Recommended Parts (Tank Assembly, 120/220 Volt).....IP30

Illustrated Parts/Recommended Parts (Tank Assembly, 100 Volt).....IP140

Illustrated Parts/Recommended Parts (Tank Assembly, 220-240 Volt)IP193

Electrical Schematic (120/220 Volt)ES27

Electrical Schematic (100 Volt)ES116

Electrical Schematic (220-240 Volt)ES28

Troubleshooting Guide (General).....TG3

Troubleshooting Guide (Triac Circuit).....TG38

Troubleshooting Guide (Diagnostics)TG11

Error CodesEC1

Product Warranty.....PW1

Contact Information

Wilbur Curtis Co., Inc.

6913 Acco Street | Montebello, CA 90640 US
 Phone: 323-837-2300 | Toll Free: 800-421-6150
 Email: csrcassistance@wilburcurtis.com | Web: www.wilburcurtis.com

For the latest specifications and information go to www.wilburcurtis.com
 Toll Free: 800-995-0417 | Monday - Friday 5:30 A.M. - 4:00 P.M. PT
 Email: techsupport@wilburcurtis.com

Due to continued product improvement, the products illustrated/photographed in this guide may vary slightly from the actual product.

Key Features

- Digital Control Module provides precise control over all brewing aspects: time, temperature, volume plus specialty coffee needs from pre-infusion to pulse-brewing to water bypass.
- Siphon Technology – During the brewing process, the brew basket’s siphon allows for the water level to rise to the perfect level without exiting. A pre-infusion in its purest form, this patented feature produces the true profile of the intended roast taste and experience.
- The Brew Basket – Uniform ridges gently hold the filter away from the sides and bottom to allow for optimum extraction. Patent pending, years went into the concept and the development of the brew basket to perfect the brewing process and provide the Golden Cup coffee results.
- Pre-Wet/Wash Filter Function – Many shops pre-wet their filters in an effort to remove any paper taste from interfering with the finished brew. The Curtis Gold Cup has a pre-wet function that streams hot water over the paper filter to eliminate any undesirable paper taste prior to brewing.

Specifications (Selected Models)

Electrical Supply Requirements

MODEL #	DESCRIPTION	PHASE	VOLTS	AMPS	HEATING CONFIG	WIRE	WATTS	HERTZ	CAPACITY
CGCx	Gold Cup Single Cup Brewer, Twin	1 PH	120/220 V	12.5/10.8 A	2 x 1450 W	2W/3W + G	1500/2379 W	50/60 Hz	4.3/5.0 gal./hr. [16.3/18.9 L/hr.]
CGC1x	Gold Cup Single Cup Brewer, Single	1 PH	120/220 V	12.5/10.8 A	2 x 1450 W	2W/3W + G	1500/2379 W	50/60 Hz	4.3/5.0 gal./hr. [16.3/18.9 L/hr.]
CGC13x	Gold Cup Single Cup Brewer, Twin, 100 Volt	1 PH	100 V	11.4 A	1 x 1600 W	2W + G	1135 W	50/60 Hz	3.0 gal./hr. [11.4 L/hr.]
CGCEx	Gold Cup Single Cup Brewer, Twin	1 PH	220-240 V	11.6-12.7 A	1 x 2500 W	2W + G (1/N/PE)	2550-3050 W	50/60 Hz	12.0 gal./hr. [45.4 L/hr.]
CGC1Ex	Gold Cup Single Cup Brewer, Single	1 PH	220-240 V	11.6-12.7 A	1 x 2500 W	2W + G (1/N/PE)	2550-3050 W	50/60 Hz	12.0 gal./hr. [45.4 L/hr.]

Dimensions

Water Supply Requirements

MODEL #	HEIGHT	WIDTH	DEPTH	SHIP WEIGHT	SHIP CUBE	WATER CONNECTOR	WATER PRESSURE	MIN. FLOW RATE
CGCx CGC1x CGC13x CGCEx CGC1Ex	18.19" [46.2 cm]	13.28" * [33.7 cm]* 15.25" ** [38.7 cm]**	20.98" [53.3 cm]	34.0 lb. [15.4 kg]	5.32 cu. ft. [0.15 m ³]	1/4" flare	20 - 90 psi [138 - 620 kPa]	1.0 gpm [3.8 Lpm]

* Without filter holster

** With filter holster

Following are the factory default settings for the brewer:

- Brew Temperature = 200°F [92°C]
- Minimum Brew Temperature = 185°F [85°C]
- Brew Volume = Large-Medium-Small
- Energy Save Mode = Off

Symbols



This is the safety alert symbol. It is used to alert you to potential physical injury hazards. Obey all safety messages that follow this symbol to avoid possible injury or death.



DANGER - Indicates a hazardous situation which, if not avoided, will result in death or serious injury.



WARNING - Indicates a hazardous situation which, if not avoided, could result in death or serious injury.



CAUTION - Indicates a hazardous situation which, if not avoided, could result in minor or moderate injury.



NOTICE - Indicates a situation which, if not avoided, could result in property damage.



IMPORTANT - Provides information and tips for proper operation.



SANITATION REQUIREMENTS



WARNING - This product can expose you to chemicals including Acrylamide and Bisphenol A (BPA), which are known to the State of California to cause cancer and birth defects or other reproductive harm. For more information visit www.P65Warnings.ca.gov.

Important Safeguards/Conventions



WARNING:

- Make sure that this appliance is installed and grounded according to the INSTALLATION INSTRUCTIONS by qualified personnel before attempting to use it. Failure to follow the INSTALLATION INSTRUCTIONS could result in personal injury or void the warranty.
- This appliance is designed for commercial use. Any service other than cleaning and preventive maintenance should be performed by an authorized Wilbur Curtis service technician.
- To reduce the risk of fire or electric shock, DO NOT open the service panels. There are no user serviceable parts inside.
- Keep hands, arms and other items away from hot surfaces of the unit during operation.
- Clean the appliance and any dispensers completely before using them for the first time according to the CLEANING INSTRUCTIONS. Clean them regularly as instructed in the CLEANING INSTRUCTIONS.
- Use this appliance only for its intended use, brewing/dispensing hot and/or cold beverages/water.
- This appliance is not intended for use by persons (including children) with reduced physical, sensory or mental capabilities or lack of experience and knowledge, unless they have been given supervision or instruction concerning use of the appliance by a person responsible for their safety. Children should be supervised to ensure that they do not play with the appliance.
- Avoid spillage onto the power (mains) connector.

CE Requirements

- This appliance must be installed in locations where it can be overseen by trained personnel.
- For proper operation, this appliance must be installed where the temperature is between 5°C to 35°C.
- This appliance is not suitable for outdoor use.
- This appliance shall not be tilted more than 10° for safe operation.
- An electrician must provide electrical service as specified in conformance with all local and national codes. For safe use, an all-pole disconnection must be incorporated into the fixed wiring in accordance with the wiring rules outlined in clause 7.12.2 of IEC 60335 for meeting the minimum electrical safety of this standard.
- This appliance must not be cleaned by water jet.
- This appliance can be used by persons aged from 18 years and above if they have been given supervision or instruction concerning use of the appliance in a safe way and if they understand the hazards involved.
- Keep the appliance and its cord out of reach of children aged less than 18 years.
- Appliances can be used by persons 18 years and above with reduced physical, sensory or mental capabilities or lack of experience and knowledge if they have been given supervision or instruction concerning use of the appliance in a safe way and understand the hazards involved.
- Children under the age of 18 years should be supervised to ensure they do not play with the appliance.
- If the power cord is ever damaged, it must be replaced by the manufacturer or authorized service personnel with a special cord available from the manufacturer or its authorized service personnel in order to avoid a hazard.
- Machine must not be immersed for cleaning.
- Cleaning and user maintenance shall not be made by children unless they are older than 18 years and supervised.
- This appliance is intended to be used in household and similar applications such as:
 - staff kitchen areas in shops, offices and other working environments;
 - by clients in hotels, motels and other residential type environments;
 - bed and breakfast type environments.
- This appliance not intended to be used in applications such as:
 - farm houses
- Access to the service areas permitted by Authorized Service personnel only.
- The A-Weighted sound pressure level is below 70 dBA.

European Regulations and Directives

- This appliance meets the requirements of all applicable regulations in Regulation 1907/2006/EU (REACH), Directive 2011/65/EU (ROHS) and its amendment (EU) 2015/863, Directive 2012/19/EU (WEEE), Directive 2014/30/EU (EMC), Directive 2006/42/EC (Machinery) and Directive 2014/35/EU (LVD).
- The declaration of conformity is included with this appliance. The appliance bears the CE mark.
- This appliance is subject to the directive on waste electrical and electronic equipment (WEEE/ EU directive). Do not dispose of this appliance in domestic waste. Contact your local governing authorities for information on disposal requirements.
- Any modifications to equipment that are not approved by the Wilbur Curtis Company will render this declaration invalid.





WARNING: Installation is to be performed only by a qualified installer.



WARNING: Improper electrical connection may result in an electric shock hazard or damage the unit. This appliance must be properly grounded.



NOTICE: DO NOT connect this appliance to a hot water supply. The water inlet valve is not rated for hot water. Do not exceed the maximum water pressure stated in the **SPECIFICATIONS** section.



IMPORTANT: Observe all governing codes and ordinances.

Installation Instructions

Installation Requirements

- A secure surface capable of supporting the weight of the appliance.
- For units without an attached cord set attached or dual voltage units set up for use with 220 - 240 Volts: Appropriately sized, UL listed, grounding type power cable to meet the electrical specifications for the appliance. If you have questions about the correct cable size and length, consult a qualified installer. If the appliance will be hard wired to a junction box, the power cable must be long enough so that the unit can be moved for cleaning underneath.
- A grounded electrical connection to an electrical circuit that meets the electrical specifications of the appliance (see **SPECIFICATIONS**). The circuit must be protected by the appropriate sized circuit breaker. If you are not certain that the existing circuit meets the requirements for your unit, consult a licensed electrician.
- A water filtration system is required to maintain trouble-free operation. Wilbur Curtis Co., Inc. recommends a Wilbur Curtis approved water filter. See the Curtis Equipment Catalog for a full line of Wilbur Curtis approved water filters.
- Potable water supply line connection from the water filter capable of supplying the minimum flow rate required by the specifications. The water supply line must be able to connect to the flare fitting on the back of the unit. See the **SPECIFICATIONS** section for the correct size. The water line should also be capable of being controlled by a shut off valve. Do not connect the water line to a saddle valve or needle valve.

IEC requires the following water connection:

- 1 A quick disconnect or additional coiled tubing (at least two times the depth of the appliance) is required so that it can be moved for cleaning underneath.
- 2 This equipment is to be installed with adequate back-flow protection to comply with applicable federal, state and local codes.
- 3 Water pipe connections and fixtures directly connected to a potable water supply shall be sized, installed and maintained in accordance with federal, state and local codes.

The International Plumbing Code of the International Code Council and the Food and Drug Administration (FDA) Food Code manual, direct that this equipment must be installed with adequate back-flow prevention in compliance with federal, state and local codes. For units installed outside of the U.S.A., make sure that the installation is in compliance with the applicable plumbing/sanitation code for your area.

Installation

**Installing the Leg Support Plate
(Optional on CGC Series Models)**



WARNING - EXCESSIVE WEIGHT: When lifting the brewer, at least two persons are required to avoid personal injury.



WARNING: The water tank must be empty before laying the brewer on its side.

For ease of installation, the brewer may be laid on its side to allow access to the bottom. Lay the unit on a soft padded surface to avoid scratches.

- 1 Remove the four legs from the bottom of the brewer by unscrewing them. The front legs are different from the rear legs. Note the location and difference between the two types during removal.
- 2 Place the leg support plate on the bottom of the unit. Line up the leg holes in the plate with the leg holes on the bottom of the unit.
- 3 Reinstall the legs in the same positions they were removed from in step 1.

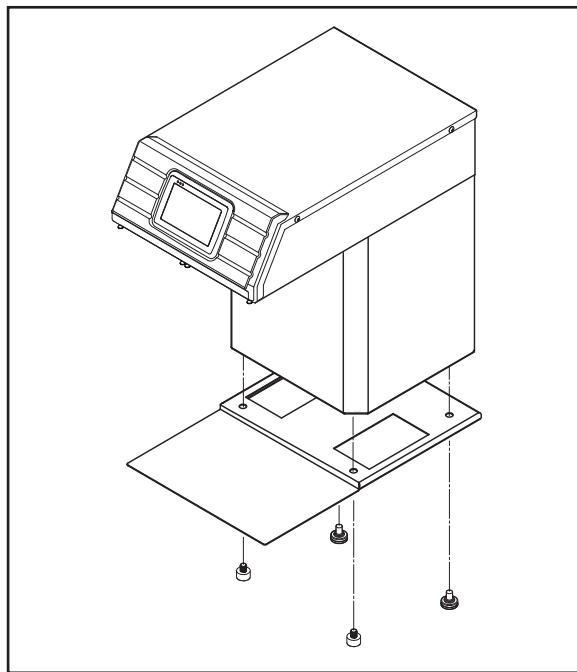

Leveling



WARNING: Use the leveling legs to level the brewer only. Do not use them to adjust brewer height. Do not extend them higher than necessary.

- 4 Position the unit on the countertop. Level it left to right and front to back by turning the bottom of the legs.

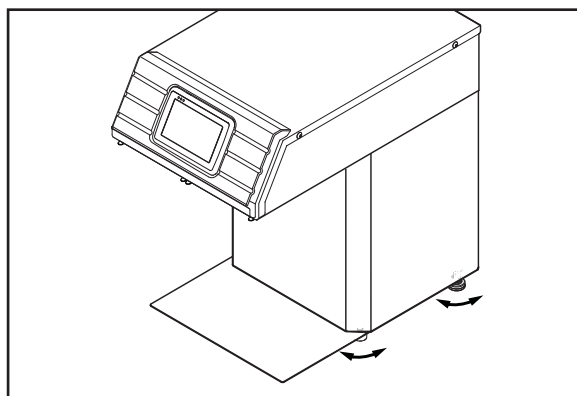

Models CGC/CGC1: Setting the Brewer for 220-240 Volt Operation (Does not apply to CGCE/CGC1E)

- 5 Remove the screws that hold the back cover in place and remove the cover.
- 6 Loosen the strain relief on the back of the brewer.
- 7 Disconnect the existing 120 Volt power cable from the terminal block and remove.
- 8 Disconnect and cap the jumper wire between the "C" and "N" terminals on the terminal block.

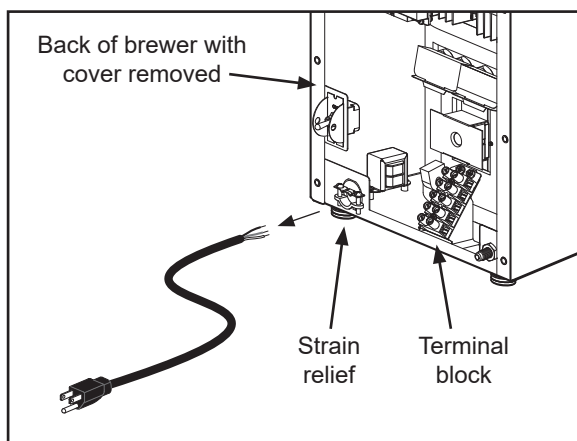

Models CGC/CGC1: Setting the Brewer for 220-240 Volt Operation (cont.)

- 9 Feed the 220-240 Volt power cable through the strain relief, into the brewer. The brewer may be wired for connection directly to a junction box or for use with a power plug that connects to an electrical outlet meeting the brewer *SPECIFICATIONS*.
- 10 Connect the wires on the power cable to the terminal block inside the brewer.
- 11 Tighten the strain relief.
- 12 Replace the back cover.

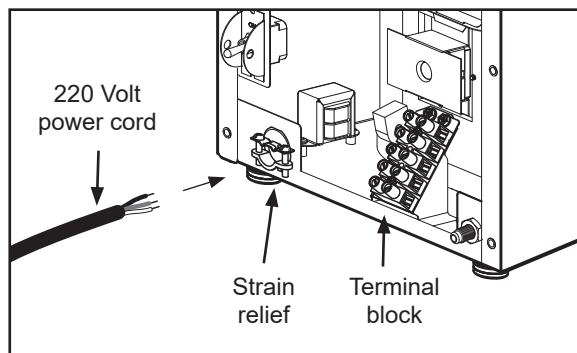

Connect the Water Supply

- 13 Flush the water supply line prior to installation to purge air and debris from the water filter and tubing.
- 14 Connect the water supply line to the flare fitting on the back of the brewer. Leave the water supply valve closed until the power is connected.

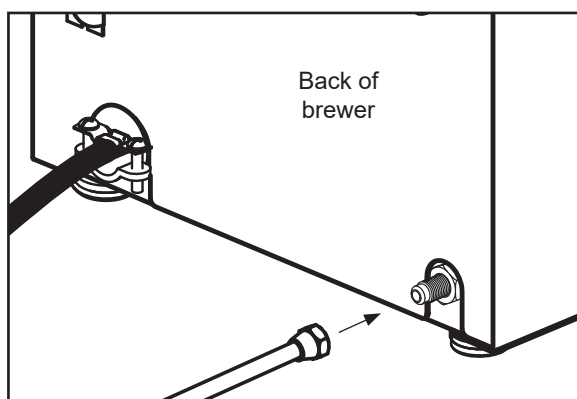

Electrical Connection

Models CGC/CGC1 - Connected to a Junction Box



WARNING: Turn off power to the junction box at the circuit breaker panel and lock out and tag the circuit breaker before connecting the power cable to the junction box.

- 15 Connect the power cable wires to the terminals in the junction box. See the *ELECTRICAL SCHEMATIC* for the power supply requirements.

Units Equipped for Connection Using a Power Plug

- 16 For models CGCE/CGC1E, connect a C20 IEC power cord (not supplied) compatible with the electrical outlet installed in the facility and that meets specifications.



WARNING: Connect the power cord only to the appropriate type and size electrical outlet. If it is not compatible, either have the cord replaced or have the electrical outlet upgraded by a licensed electrician. Do not use an extension cord. Do not use a power cord/plug that is damaged.

- 17 Connect the power cord to the appropriate electrical outlet.

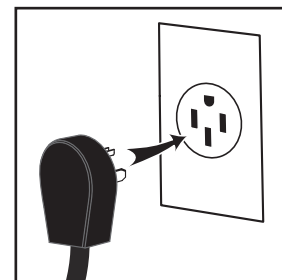
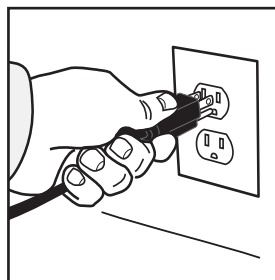
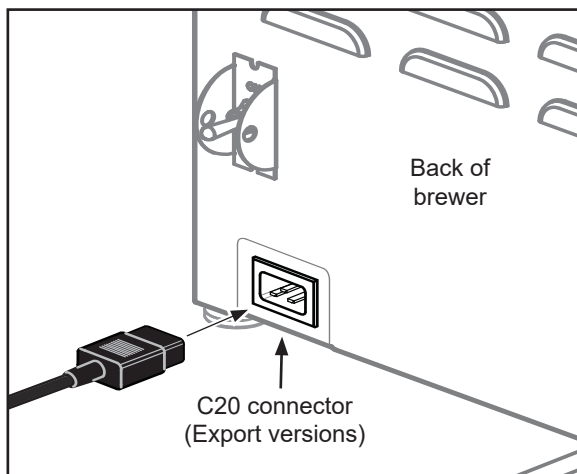

Power Up the Brewer

- 18 Turn on the water supply valve.
- 19 Make sure that the circuit breaker supplying power to the unit is on.
- 20 Turn the toggle switch on the back of the brewer to the ON position. The water tank will start to fill. While the tank is filling, inspect the water supply line for leaks.
- 21 When the water in the tank rises to the correct level, the heating elements will turn on automatically. Depending on the incoming water temperature and the electrical specifications, the water tank typically requires 20 to 30 minutes to reach the factory set operating temperature. When the water has heated, **Ready to brew** will be displayed on the LCD screen.

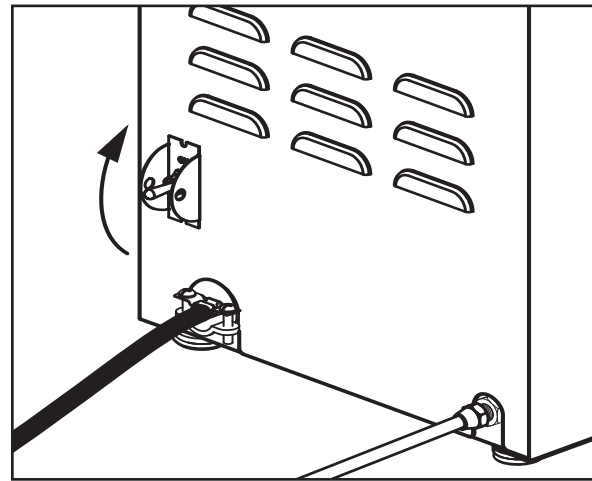

i **IMPORTANT:** When operating the brewer at higher elevations, reduce the factory set operating temperature (200°F/92°C) by 2°F/1°C for each 1000 ft./300 m of elevation above 4000 ft./1200 m. See the *PROGRAMMING GUIDE* section.

- 22 Perform a brew cycle of a least 12 oz./350 ml to purge any remaining air from the system. See *OPERATING INSTRUCTIONS*. During the initial brew cycle and whenever the filter is replaced, you may hear the sounds of air being purged from the filter, tubing and water tank. Fill a coffee cup with water, using the hot water faucet, to purge air from the hot water line.

Brewing Instructions - Single Cup

WARNING - TO AVOID SCALDING, AVOID SPLASHING. Keep body parts clear of the brewer during brewing. Do not remove the brew basket while "Brewing" appears on the display.

The CGC G4 Brewer is factory preset for optimal performance.

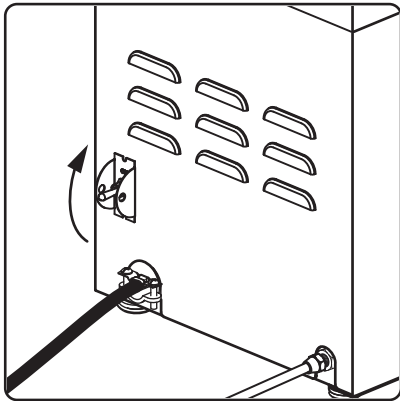

1 The brewer should be ON. Confirm this at the toggle switch on the back. "Ready to brew" should be on the display.

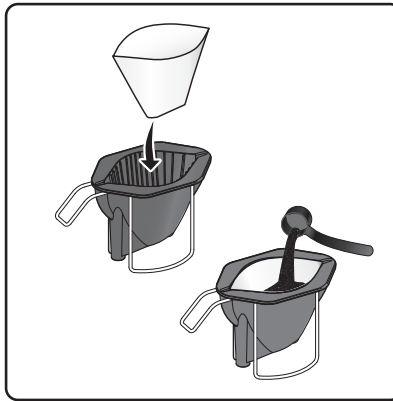

2 Insert a clean paper filter into the brew basket. Fill with the proper amount of coffee. Level the coffee in the filter.

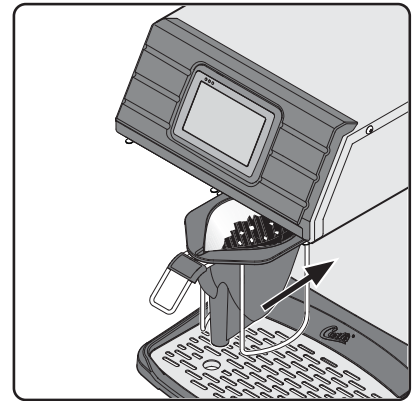

3 Slide the filled brew basket into the brew rails on the brewer. Slide it all the way back until it stops.

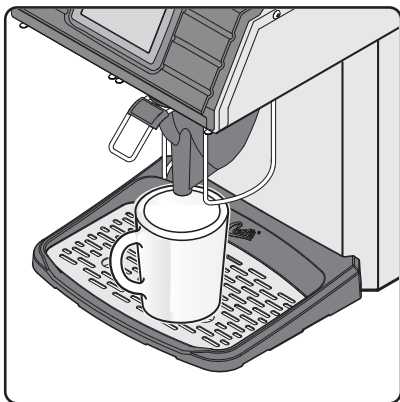

4 Center an empty coffee container beneath the brew basket.

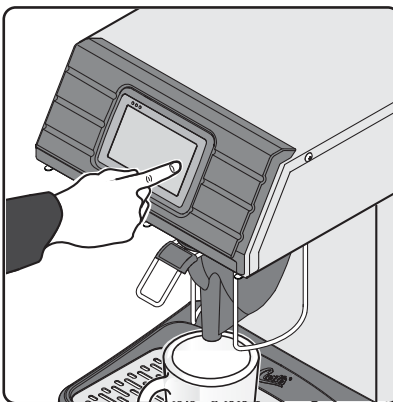

5 Hold your finger on the appropriate brew icon. As soon as you hear the click of the brew valve, lift your finger. Brewing will begin.

ENTER BREW CODE		
1	2	3
4	5	6
7	8	9
Del	0	OK

6 If a keypad appears on the display, the brew code feature is enabled (default is off). **Brewing will start immediately after you enter the brew code.** See the *PROGRAMMING GUIDE* to set up/disable the brew code.

The brewer will brew coffee based on the settings programmed into the universal control module (UCM). To change the settings, see the *PROGRAMMING GUIDE* section. During the brew cycle, an on screen brew timer will count down the time remaining.

Brewing Instructions - Dripper

WARNING - TO AVOID SCALDING, AVOID SPLASHING. Keep body parts clear of the brewer during brewing. Do not remove the dripper while “Brewing” appears on the display.

The CGC G4 Brewer is factory preset for optimal performance.

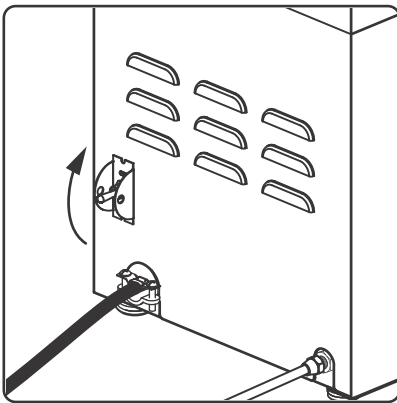

1 The brewer should be ON. Confirm this at the toggle switch on the back. “Ready to brew” should be on the display.

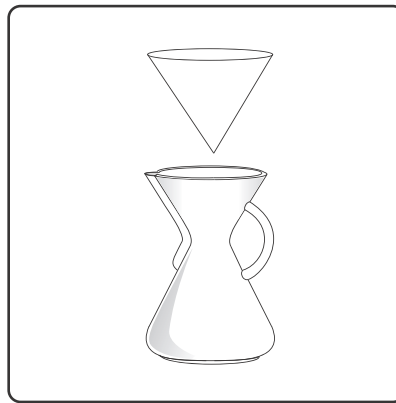

2 Insert a clean paper filter into the dripper.

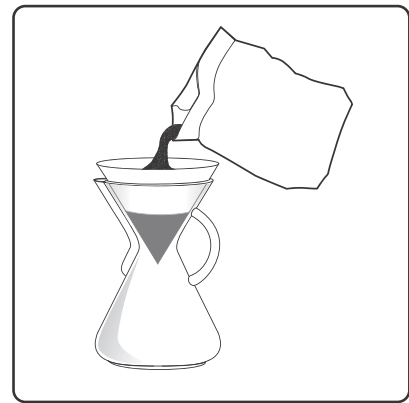

3 Fill the dripper with the proper amount of coffee. Level the coffee in the filter.

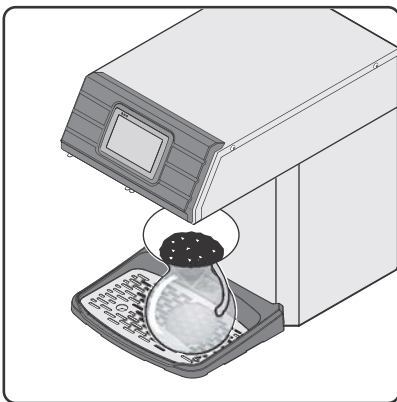

4 Remove the brew basket and center the dripper beneath the spray head. NOTE: The spray head location varies with model.



5 Hold your finger on the appropriate brew icon. As soon as you hear the click of the brew valve, lift your finger. Brewing will begin.

ENTER BREW CODE		
1	2	3
4	5	6
7	8	9
Del	0	OK

6 If a keypad appears on the display, the brew code feature is enabled (default is off). **Brewing will start immediately after you enter the brew code.** See the *PROGRAMMING GUIDE* to set up/disable the brew code.

The brewer will brew coffee based on the settings programmed into the universal control module (UCM). To change the settings, see the *PROGRAMMING GUIDE* section. During the brew cycle, an on screen brew timer will count down the time remaining.

Brewing Instructions - Pourpot (Model CGC1 only)

WARNING - TO AVOID SCALDING, AVOID SPLASHING. Keep body parts clear of the brewer during brewing. Do not remove the pourpot while "Brewing" appears on the display.

The CGC G4 Brewer is factory preset for optimal performance.

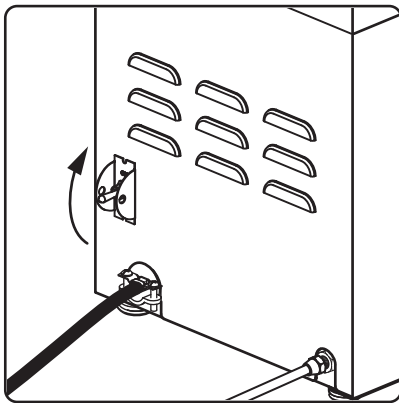

1 The brewer should be ON. Confirm this at the toggle switch on the back. "Ready to brew" should be on the display.

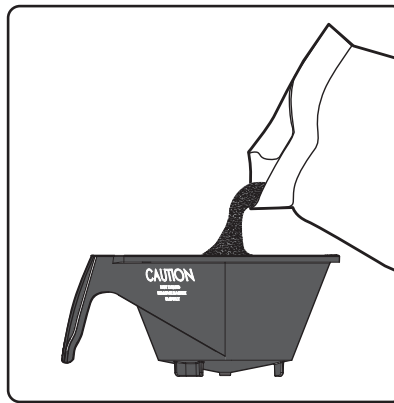

2 Insert a clean paper filter into the multi-cup brew basket. Fill with the proper amount of coffee. Level the coffee in the filter.



3 Slide the filled brew basket into the brew rails on the brewer. Slide it all the way back until it stops.

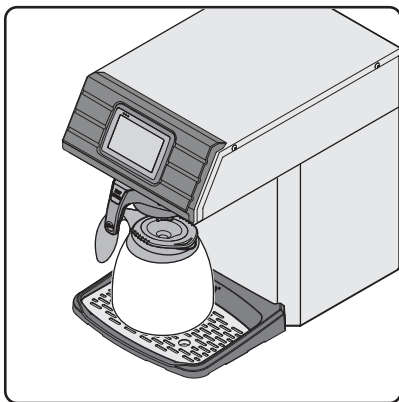

4 Center an empty pourpot beneath the brew basket. For best results, pre-heat the pourpot with 12 oz. (350 ml) minimum of hot water for 20 seconds, then dump out.

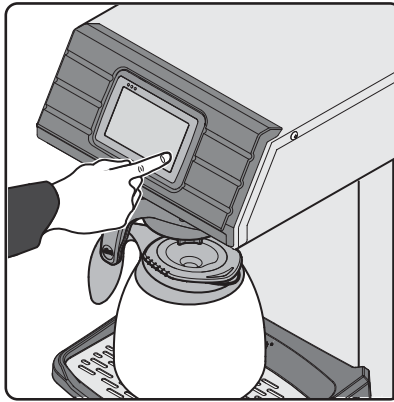

5 Hold your finger on the appropriate brew icon. As soon as you hear the click of the brew valve, lift your finger. Brewing will begin.

ENTER BREW CODE		
1	2	3
4	5	6
7	8	9
Del	0	OK

6 If a keypad appears on the display, the brew code feature is enabled (default is off). **Brewing will start immediately after you enter the brew code.** See the *PROGRAMMING GUIDE* to set up/disable the brew code.

The brewer will brew coffee based on the settings programmed into the universal control module (UCM). To change the settings, see the *PROGRAMMING GUIDE* section. During the brew cycle, an on screen brew timer will count down the time remaining.



WARNING: HOT SURFACES - To avoid injury, allow the brewer and dispenser(s) to cool before cleaning.



NOTICE - Do not use cleaning liquids, compounds or powders containing chlorine (bleach) or corrosives. These products promote corrosion and will damage the finishes. **USE OF THESE PRODUCTS WILL VOID THE WARRANTY.**

Cleaning The Brewer - Daily



WARNING: DO NOT immerse the brewer in water or any other liquid.

The brewer should be OFF. Turn the brewer off by flipping the rear toggle switch to the OFF position.

- 1 Remove the dispenser(s). Wipe exterior brewer surfaces with a damp cloth to remove spills and debris.
- 2 Remove the brew basket(s) and clean them in a mild detergent solution. Use a soft bristled brush for hard to clean areas. Rinse with clean water, then dry.
- 3 Wipe the spray head area with a cloth soaked in a mild detergent solution. Rinse with a cloth soaked with clean water removing any residual detergent. Use a clean, soft cloth to dry.
- 4 Dump out the drip tray(s) (if applicable). Rinse with clean water, then dry with a soft, clean cloth.

Cleaning The Brewer - Weekly

The brewer should be OFF. Turn the brewer off by flipping the rear toggle switch to the OFF position.

- 1 Remove the spray head(s), unscrewing counterclockwise from the dome plate.
- 2 Thoroughly clean and rinse the dome plate area.
- 3 Clean the brew basket rails with a brush soaked with a mild detergent solution. Rinse the area with a cloth soaked with clean water, removing any residual detergent.
- 4 Dry the area with a soft, clean cloth.
- 5 Reattach the spray head(s).

Cleaning Single Cup Brew Baskets

Clean the dispensing spout of the brew basket once a month or more often in locations where the brewer gets heavy use.

- 1 Look into the brew basket to locate the cap covering the spout tube. Remove this cap by grasping the top portion and pulling it straight up.
- 2 Clean the inside orifice of the spout tube. For better cleaning, you can mix a mild dish washing solution to use while cleaning. Insert a small brush through the spout tube from the outside of the brew basket. Spin the brush a few times to remove any coffee residue. Look inside the brew basket and verify that the brush has gone completely through the spout.
- 3 Clean the small opening on the side of the spout tube. Insert the brush into the side opening and spin it a few times. Run the brush completely through the side opening.
- 4 Rinse the brew basket with clear water. Observe the flow of water from the dispensing spout to make sure you have a good flow. Replace the cap on top of the spout tube. Push down on the cap until it snaps into place.

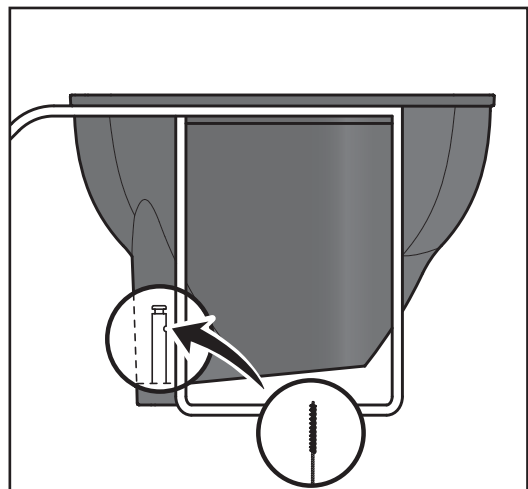
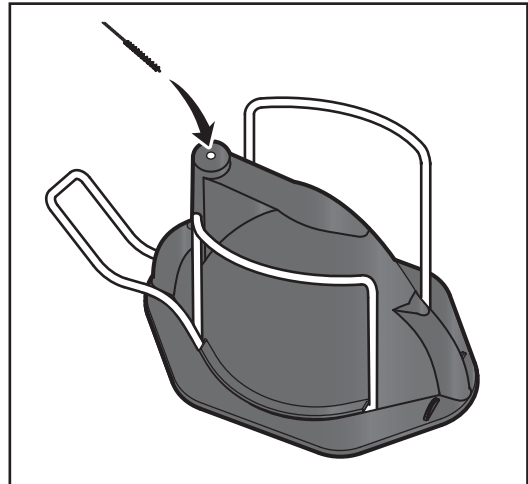
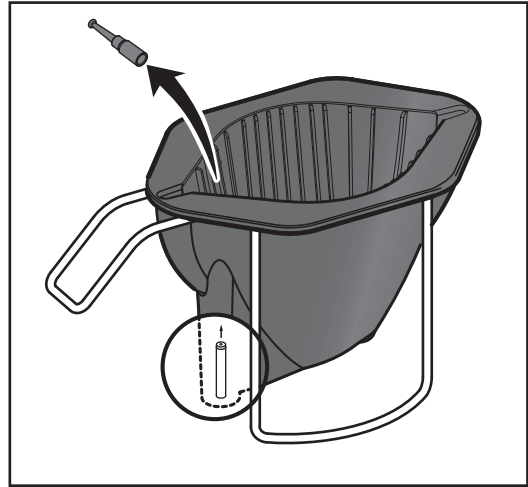

Touchscreen Control Module Overview

The touchscreen turns on whenever the rear toggle switch is on. The symbol buttons on the screen control operation and programming. Pressing the on-screen symbols and buttons with your finger tip activates the various functions. The default screen, as well as additional control buttons are shown below.

There are two methods for changing the default settings on G4 brewers. The settings can be programmed manually using the brewer touch screen (see below), or automatically using the USB (Universal Serial Bus) data port on the side of the brewer (see *Automatic Programming - USB*).

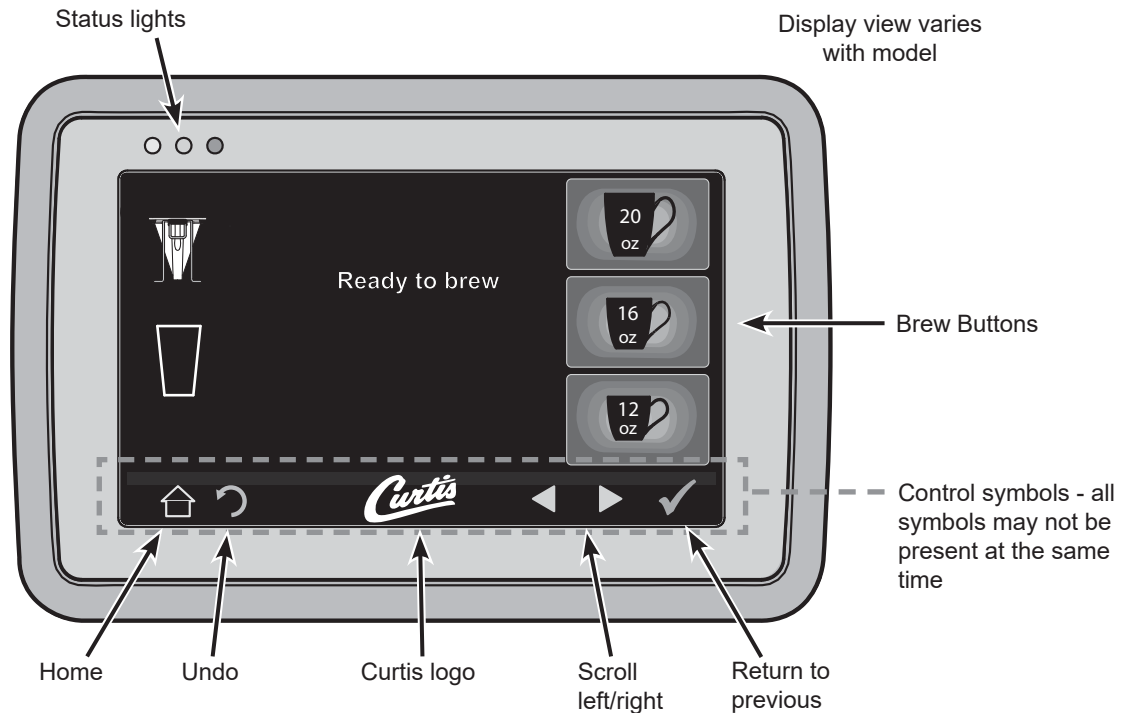

Manual Programming Mode

- 1 Tap the (white) Curtis logo on the touchscreen five (5) times to enter programming mode.

ENTER ACCESS CODE		
1234		
1	2	3
4	5	6
7	8	9
Del	0	OK



- 2 The ACCESS CODE screen will appear. The default pass code is 1 2 3 4. Once the code is entered, press OK. The MAIN MENU screen will appear. The access code can be reset in the Control Settings sub-menu, under Passwords.

- 3 The MAIN MENU screen contains a series of sub-menu icons. The icons vary based on the model selected under the Model Select sub-menu. For the brewer to operate properly, the model selected must match the model series on the brewer model number label affixed to the outside of the machine.

Manual Programming Mode (cont.)

Shown below and on the following pages are the sub-menus available for the programming MAIN MENU. The icons and programming options that appear vary based on the brewer model selected under Model Select.

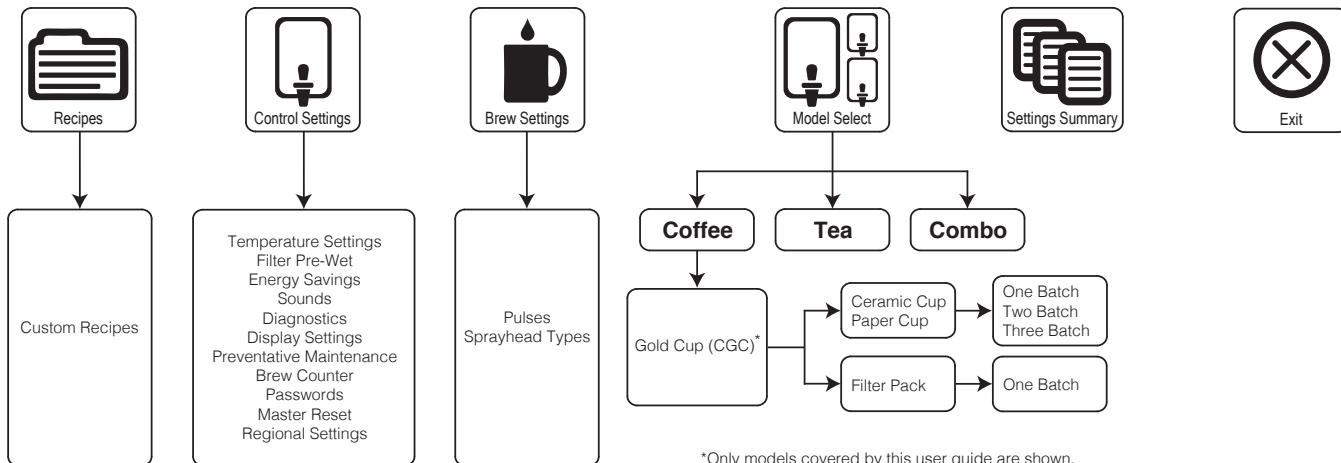

Recipes Menu

Enter the Custom Recipe sub-menu. Below and on the following pages are the current factory default recipe settings as of the date of printing.

Recipe Defaults - CGC (Twin) - Paper/Ceramic Cup - Purple Spray Head - 20 oz. (Three Batch)													
Pulse	1	2	3	4	5	6	7	8	9	10	11	12	Total
On	11	5	5	4	4	4	4	3	2	2	4		0:48
oz.	4.62	2.10	2.10	1.68	1.68	1.68	1.68	1.26	0.84	0.84	1.68		20.2
Off	15	17	17	17	12	12	15	13	8	1	1		2:08
												Total Brew Time	3:36
												Drip Out	0:40

Recipe Defaults - CGC (Twin) - Paper/Ceramic Cup - Purple Spray Head - 16 oz. (Two Batch)													
Pulse	1	2	3	4	5	6	7	8	9	10	11	12	Total
On	11	5	5	4	4	4	5						0:38
oz.	4.62	2.10	2.10	1.68	1.68	1.68	2.10						16.0
Off	15	17	17	17	12	12	1						1:31
												Total Brew Time	2:49
												Drip Out	0:40

Recipe Defaults - CGC (Twin) - Paper/Ceramic Cup - Purple Spray Head - 12 oz. (One Batch)													
Pulse	1	2	3	4	5	6	7	8	9	10	11	12	Total
On	11	5	5	4	4								0:29
oz.	4.62	2.10	2.10	1.68	1.68								12.2
Off	15	17	17	17	1								1:07
												Total Brew Time	2:06
												Drip Out	0:30

continued...

Recipes Menu (cont.)

Recipe Defaults - CGC (Twin) - Paper/Ceramic Cup - Gray Spray Head - 20 oz. (Three Batch)													
Pulse	1	2	3	4	5	6	7	8	9	10	11	12	Total
On	12	6	6	5	5	5	5	4	2	2	1		0:53
oz.	4.56	2.28	2.28	1.90	1.90	1.90	1.90	1.52	0.76	0.76	0.38		20.1
Off	15	17	17	17	12	12	15	13	8	1	1		2:08
Total Brew Time													3:36
Drip Out													0:40

Recipe Defaults - CGC (Twin) - Paper/Ceramic Cup - Gray Spray Head - 16 oz. (Two Batch)													
Pulse	1	2	3	4	5	6	7	8	9	10	11	12	Total
On	12	6	6	5	5	5	4						0:43
oz.	4.62	2.28	2.28	1.90	1.90	1.90	1.52						16.0
Off	15	17	17	17	12	12	1						1:31
Total Brew Time													2:54
Drip Out													0:40

Recipe Defaults - CGC (Twin) - Paper/Ceramic Cup - Gray Spray Head - 12 oz. (One Batch)													
Pulse	1	2	3	4	5	6	7	8	9	10	11	12	Total
On	12	6	6	4	4								0:32
oz.	4.56	2.28	2.28	1.52	1.52								12.2
Off	15	17	17	17	1								1:07
Total Brew Time													2:09
Drip Out													0:30

Recipe Defaults - CGC (Twin) - Filter Pack - Purple Spray Head - 12 oz. (One Batch)													
Pulse	1	2	3	4	5	6	7	8	9	10	11	12	Total
On	5	2	2	2	2	2	2	2	2	2	2	4	0:29
oz.	2.10	0.84	0.84	0.84	0.84	0.84	0.84	0.84	0.84	0.84	0.84	1.68	12.2
Off	5	5	5	5	5	5	5	5	5	5	5	0	0:55
Total Brew Time													1:54
Drip Out													0:30

Recipe Defaults - CGC (Twin) - Filter Pack - Gray Spray Head - 12 oz. (One Batch)													
Pulse	1	2	3	4	5	6	7	8	9	10	11	12	Total
On	6	3	3	2	2	2	2	2	2	2	2	4	0:32
oz.	2.28	1.14	1.14	0.76	0.76	0.76	0.76	0.76	0.76	0.76	0.76	1.52	12.2
Off	5	5	5	5	5	5	5	5	5	5	5	0	0:55
Total Brew Time													1:57
Drip Out													0:30

continued...

Recipes Menu (cont.)

Recipe Defaults - CGC1 (Single) - Purple Spray Head - 60 oz. (Three Batch)													
Pulse	1	2	3	4	5	6	7	8	9	10	11	12	Total
On	143												2:23
oz.	60.1												60.1
Off	0												0:00
Total Brew Time													4:23
Drip Out													2:00

Recipe Defaults - CGC1 (Single) - Purple Spray Head - 20 oz. (Two Batch)													
Pulse	1	2	3	4	5	6	7	8	9	10	11	12	Total
On	11	5	5	4	4	4	4	3	2	2	4		0:48
oz.	4.62	2.10	2.10	1.68	1.68	1.68	1.68	1.26	0.84	0.84	1.68		20.2
Off	15	17	17	17	12	12	15	13	8	1	1		2:08
Total Brew Time													3:36
Drip Out													0:40

Recipe Defaults - CGC1 (Single) - Purple Spray Head - 12 oz. (One Batch)													
Pulse	1	2	3	4	5	6	7	8	9	10	11	12	Total
On	11	5	5	4	4								0:29
oz.	4.62	2.10	2.10	1.68	1.68								12.2
Off	15	17	17	17	1								1:07
Total Brew Time													2:06
Drip Out													0:30

Recipe Defaults - CGC1 (Single) - Gray Spray Head - 60 oz. (Three Batch)													
Pulse	1	2	3	4	5	6	7	8	9	10	11	12	Total
On	150	8											2:38
oz.	57.00	3.04											60.0
Off	0	0											0:00
Total Brew Time													4:38
Drip Out													2:00

Recipe Defaults - CGC1 (Single) - Gray Spray Head - 20 oz. (Two Batch)													
Pulse	1	2	3	4	5	6	7	8	9	10	11	12	Total
On	12	6	6	5	5	4	4	3	2	2	4		0:53
oz.	4.56	2.28	2.28	1.90	1.90	1.52	1.52	1.14	0.76	0.76	1.52		20.1
Off	15	17	17	17	12	12	15	13	8	1	1		2:08
Total Brew Time													3:41
Drip Out													0:40

Recipe Defaults - CGC1 (Single) - Gray Spray Head - 12 oz. (One Batch)													
Pulse	1	2	3	4	5	6	7	8	9	10	11	12	Total
On	12	6	6	4	4								0:32
oz.	4.56	2.28	2.28	1.52	1.52								12.2
Off	15	17	17	17	1								1:07
Total Brew Time													2:09
Drip Out													0:30

Control Settings Menu

Temperature - sets the brewing temperature of the water held in the water tank. The factory default setting is 200°F/92°C. The setting range is 160°F to 206°F (71°C to 97°C).

Filter Pre-Wet Time - streams hot water over the paper filter to eliminate undesirable paper taste prior to brewing. The factory default setting is Disabled. The setting range is 4 to 20 seconds.

Energy Save Mode - saves energy during periods of non-use. The factory default setting is No Change [energy save off]. The setting options are No Change, turn off the heating element after four hours of non-use or reduce the heating element temperature to 140°F (60°C) after four hours of non-use.

Sounds - turns the beeper heard each time a button is pressed, on or off. The factory default setting is On.

Diagnostics - runs the system auto-test. See the *Troubleshooting Guide* for more details.

Display Settings

- **Brew Timer** - turns the brew timer on the display on and off. The factory default setting is Show.
- **Brew Volume** - “Show” displays Oz. or mL, “Hide” displays SM, MD and LG. The factory default setting is Show. Units set to 1 Batch display “Brew”.
- **Screen saver** - Turns the display screen saver on and off. The factory default setting is Off.
- **Display Name** - changes the company name on the display. The factory default setting is blank.
- **Brew button icon** - selects the icons used on the display. The factory default setting is “original”.

Preventive Maintenance

- **Maintenance Interval** - turns on/off and adjusts the preventive maintenance brew monitor. The factory default setting is Disabled. When Enabled, the UCM measures the number of gallons brewed before the maintenance reminder is displayed. The setting range is 25 to 3,000 gal. (95 to 11,350 L).
- **Service Telephone Number** - sets the service phone number that appears on the display when the UCM detects an error condition. The factory default is 1-800-000-0000.

Brew Counter - When accessed, this feature displays the total number of brew cycles and the resettable brew cycle counter (number of brew cycles since last reset).

Passwords

- **Programming Password** - changes the programming menu password. Always active. The factory default is 1234.
- **Brew Password** - turns the brew access password feature on and off and is used to create the brew password. This feature prevents brewing by unauthorized persons. The factory default setting is Disabled. When Enabled, an access code keypad appears on the screen when the brew button is pressed. The correct access code must be entered before brewing will proceed.
- **USB Password** - turns the USB screen access password on and off and is used to create the USB access password. This feature prevents access by unauthorized persons to the USB programming screens. The factory default setting is Disabled. When Enabled, an access code keypad appears on the screen when the user attempts to access the USB menus.

Master Reset - resets the brewer universal control module (UCM) to the factory default settings.

Regional Settings

- **SI/US** - switches the brewer unit settings between US and metric. The factory default setting is US.
- **Language** - changes the language that appears on the display. The factory default setting is English.

Brew Settings Menu

When you first enter the Brew Settings programming menu, you will be asked to select (press) a BREW button to change the settings for. To program more than one BREW button, finish programming the first, then **reenter the Brew Settings menu to program the second.**

Pulse Brew - selects the pulse brew pattern, The factory default setting is E. The pulse brew pattern selected “tunes” or changes the flavor of the coffee. If energy saver mode is on, after pressing the brew button, the brew cycle will start when the water in the tank reaches brewing temperature.

Pulse Brew Guidelines

- Filter pack type coffees typically extract better with the A and B pulse setting.
- Decaffeinated coffees typically extract better with the B pulse setting.
- High-yield coffees typically extract better with the C pulse setting. Of course, any of the A, B or C settings may be used to suit your taste profile.
- Settings D and E are manual pulse counts.

Setting	Description
A	Toward the beginning of brew cycle: 4 cycles of 10 seconds on and 10 seconds off, then on until end of brew cycle.
B	Starts towards ends of brew cycle. 4 cycles of 10 seconds off and 4 cycles of 10 seconds on. Ends when brew cycle ends.
C	Starts at beginning of brew cycle. 5 cycles of 25 seconds on and 20 seconds off, then on until end of brew cycle.
D	Manually set. Starts at beginning of brew cycle. Number of pulses is adjustable from 1 to 12. Pulse on time and off time are both adjustable from 5 to 150 seconds.
E	Manually set.* Starts at beginning of brew cycle. Number of pulses is adjustable from 1 to 12. Pulse on time and off time are both adjustable from 1 to 150 seconds.

*See *Recipe Settings*, earlier in this section, for the various default manual settings for CGC series brewers.

Drip-out Mode - sets the drip-out mode timer. After water stops flowing, it allows additional time for the coffee to drain before the brew basket lock releases. This feature reduces the chance that the brew basket will be removed too early. The setting range is 0 seconds to 15 minutes. See *Recipe Settings*, earlier in this section, for the default settings for CGC series brewers.

Automatic Programming - USB

Using the USB connection and a flash drive easily reprograms the settings by simply copying data.

A flash drive can copy all of the settings from one identical G4 brewer to another. Doing so eliminates the need to program each step individually using the touchscreen. This process also makes it easy to quickly standardize the program settings on multiple G4 brewers.

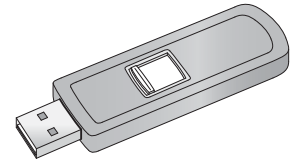

Use a flash drive that supports USB 2.0 or above and has a type-A USB connection. The storage capacity must be 2 GB minimum.

i IMPORTANT: The flash drive must be completely blank. Erase any existing files on the drive before starting the following process.

Uploading the Software to the Flash Drive

- 1 Make sure the brewer is on. Check to make sure that the brewer you are copying settings from is programmed as desired.
- 2 Open the cover on the USB port and insert the connector on the empty flash drive. The port is located on the right side panel of the brewer, near the top. The universal control module (UCM) will upload all of the setup data onto the flash drive. The yellow LED icon on the top left of the touchscreen will light indicating that data is transferring. This process will only take a second to complete.

Downloading the Software to the Brewer from the Flash Drive

- 1 Select the (identical) brewer you wish to make program changes to. The brewer must be on.
- 2 Plug the loaded flash drive into the USB port on the brewer. The data copied from the first brewer will automatically download, overwriting all the settings that were on the second brewer.
- 3 The red LED on the top left of the touchscreen will indicate that the download is in process. This will only take a second.
- 4 Once the download is complete, the UCM will reboot so that the changes take effect.
- 5 Remove the flash drive. The download is complete. The data on the flash drive can continue to be downloaded into as many identical brewers as needed.

USB File Transfer

This screen will be present whenever the USB flash drive is inserted, provided the brewer is not currently brewing.

The default action is “No Action”. The UCM will always create a backup on the flash drive before downloading settings/recipes or a screen-saver.

If a firmware update is present on the flash drive, the firmware update procedure will be started before the screen is shown.

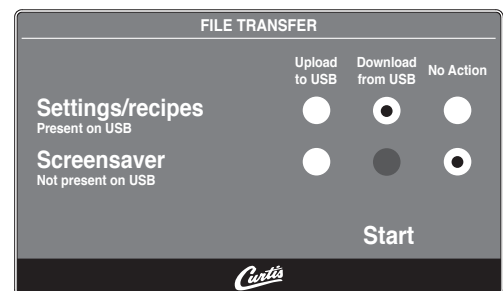

CGC Series - G4 Digital Brewing System

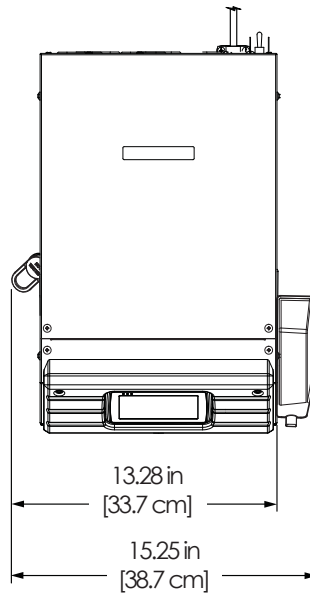

Top View - CGC, CGC1, CGCE

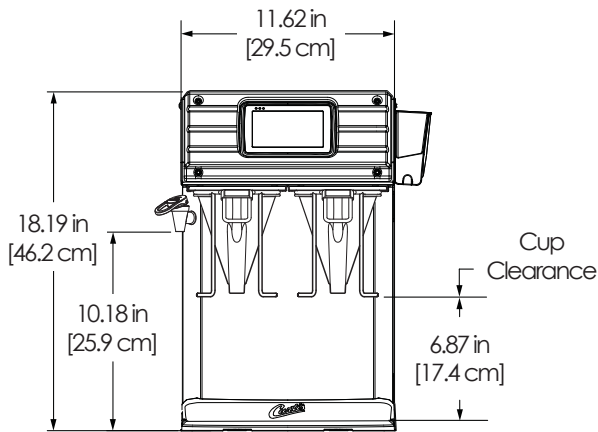

Front View - CGC, CGCE

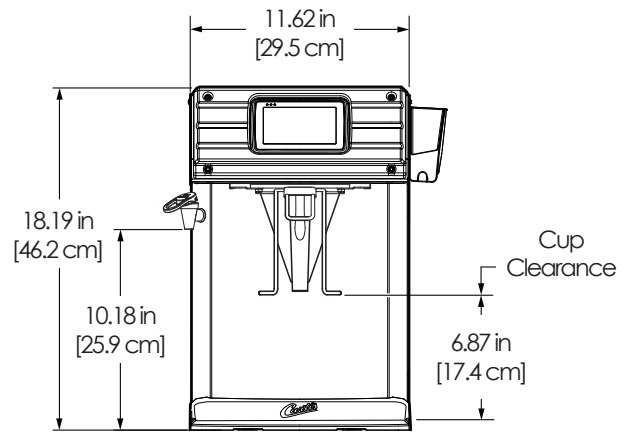

Front View - CGC1

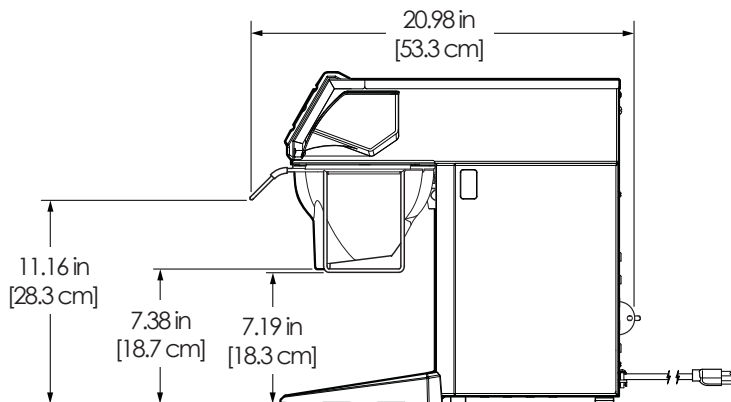

Side View - CGC, CGC1, CGCE

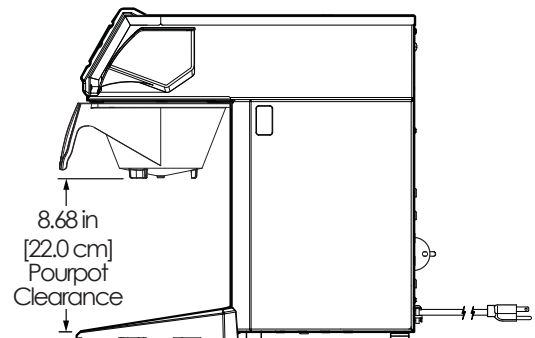

Side View - CGC1 with Large Brew Basket

CGC Series - Main Chassis - Exploded View

Water tanks assemblies:
 120/220 Volt, see section IP30
 100 Volt, see section IP140
 220-240 Volt, see section IP193

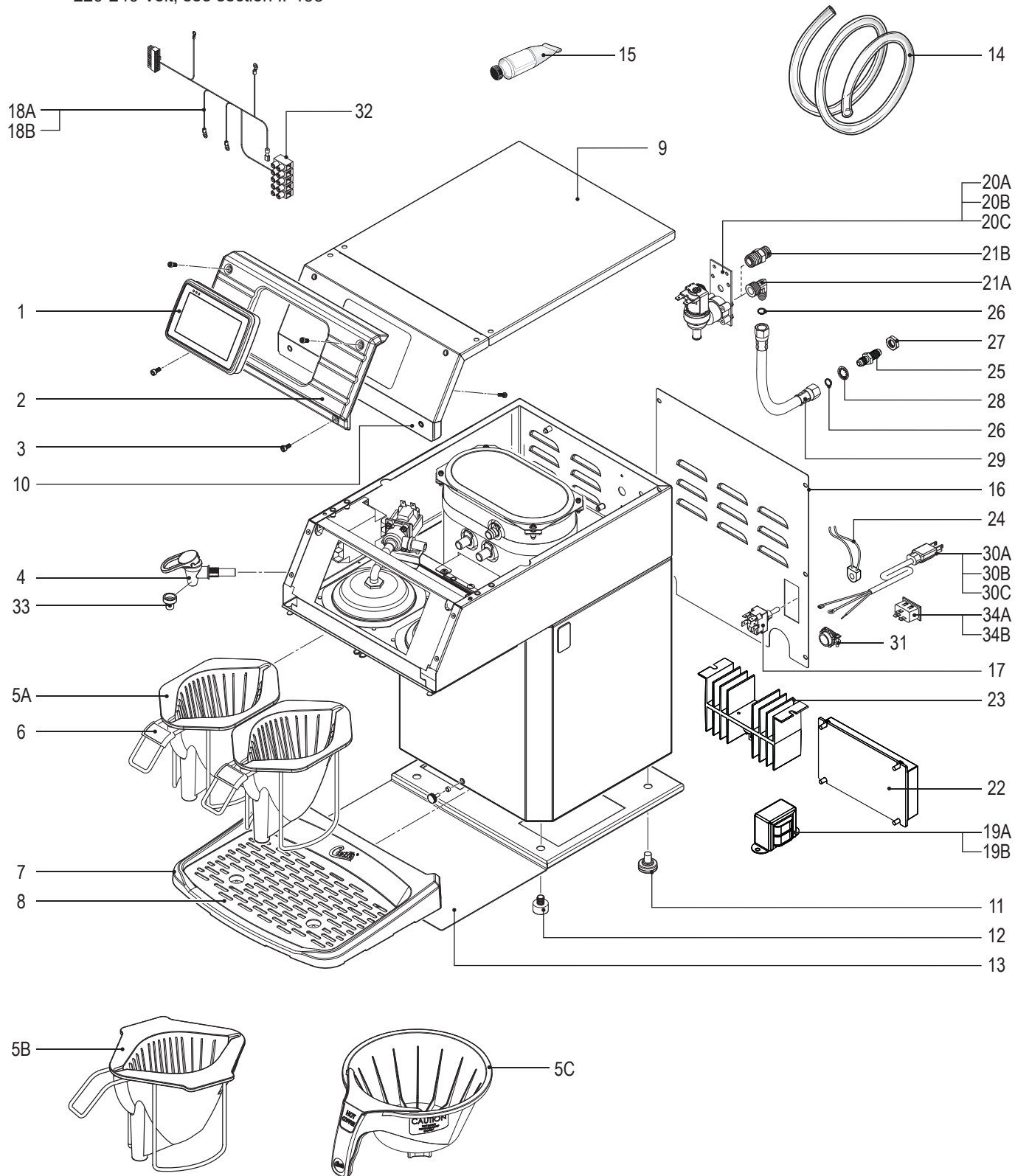

CGC Series - Main Chassis - Parts List

ITEM #	PART #	DESCRIPTION
1	WC-10000*	CONTROL MODULE, TOUCH SCREEN
2	WC-66081	BEZEL, FRONT CGC
3	WC-4426	SCREW, 8-32x3/8 PH HEAD TRUSS
4	WC-1809-P*	FAUCET, PS/HPS SERIES HOT WATER
5A	WC-3411	BREW CONE, ASSY, CGC
5B	WC-3411-101	BREW CONE, ASSY CGC1
5C	WC-3621-101-P	BREW CONE, UNIVERSAL
6	WC-66082	FLAVOR, CLIP BREWCONE CGC
7	WC-66070	PAN, DRIP TRAY CGC
8	WC-66085	SCREEN, DRIP TRAY CGC
9	WC-61492-103	COVER, TOP BACK CGC
10	WC-61492-102	COVER, TOP FRONT CGC
11	WC-3518*	LEG, GLIDE 3/8"-16 STUD SCREW
12	WC-3503*	LEG, 3/8"-16 STUD SCREW BUMPER
13	WC-61497	PLATE, LEG SUPPORT CGC
14	WC-5310	TUBE, 5/16 ID x 1/8W SILICONE GEN USE
15	WC-5231	COMPOUND, HEAT SINK 5OZ
16	WC-61491-102	COVER, BACK CGC
16A	WC-61491-103	COVER, BACK CGCEX/CGC1EX
17	WC-103	SWITCH, TOGGLE DPST 25A-125/250VAC
18A ^{a,b}	WC-13443	HARNESS, ASSY COMPLETE CGC
18B ^{c,d,e}	WC-13443-101	HARNESS ASSY, COMPLETE CGCE
19A ^{a,b,e}	WC-589-101	TRANSFORMER,120VAC-24V 4.8A
19B ^{c,d}	WC-589-102	TRANSFORMER,240VAC-24V 4.8A

ITEM #	PART #	DESCRIPTION
20A ^{a,b}	WC-826L*	VALVE, INLET 1 GPM 120V 9W
20B ^{c,d}	WC-856	VALVE, INLET 1 GPM 240V 6W
20C ^e	WC-847*	VALVE, INLET 2 GPM 120V 9W
21A	WC-2401-P	ELBOW, 3/8 NPT X 1/4 FLRE PLTD PLATED
21B	WC-29149	FITTING, ADAPTER 3/8IN MNPT X G3/8 BSPP SS
22	WC-10001*	CONTROL MODULE, UPM 120/220V
23	WC-8556*	HEATSINK, ASSY DV
24	WC-14045-101	CURRENT SENSOR ASSY G4
25	WC-29074	FITTING, 1/4" FLARE BULKHEAD UNION SS.
26	WC-43811	GASKET, 1/4 NYLON FLARE
27	WC-4279	NUT, 7/16-20 UNF-2B THD
28	WC-43143	WASHER, .44D X .75 O.D INTERNAL LOCK
29	WC-53169-12	TUBE ASSY, BRAIDED 1/4 FLARE X 11-1/4" LG
30A ^{a,b}	WC-1200	CORD, 14/3 SJTO 6' BLK W/PLUG
30B ^c	WC-1231-102	CORD, 2.5 mm ² 90°C 36A 450/750 V
30C	WC-1256	CORD, 1.5mm ² X 3 W/GB-2099 & C19 CHINA
31 ^{a,b,c}	WC-1412	CORD GRIP, 3/4"
32	WC-314	POWER BLOCK, 5 STATION
33	WC-1806*	SEAT CUP, SILICONE USE ON WC-1809 FAUCET
34A ^d	WC-1522	SOCKET, POWER INLET 16A/250V SNAP-IN (C20)
34B ^e	WC-1525	SOCKET, POWER INLET 15A/250V SNAP-IN (C14)

*Recommended parts to stock

^aCGCx

^bCGC1x

^cCGCEx, CGC1Ex (older units)

^dCGCEx, CGC1Ex (newer units)

^eCGC13x

CGC Series - Top Wrap - Exploded View

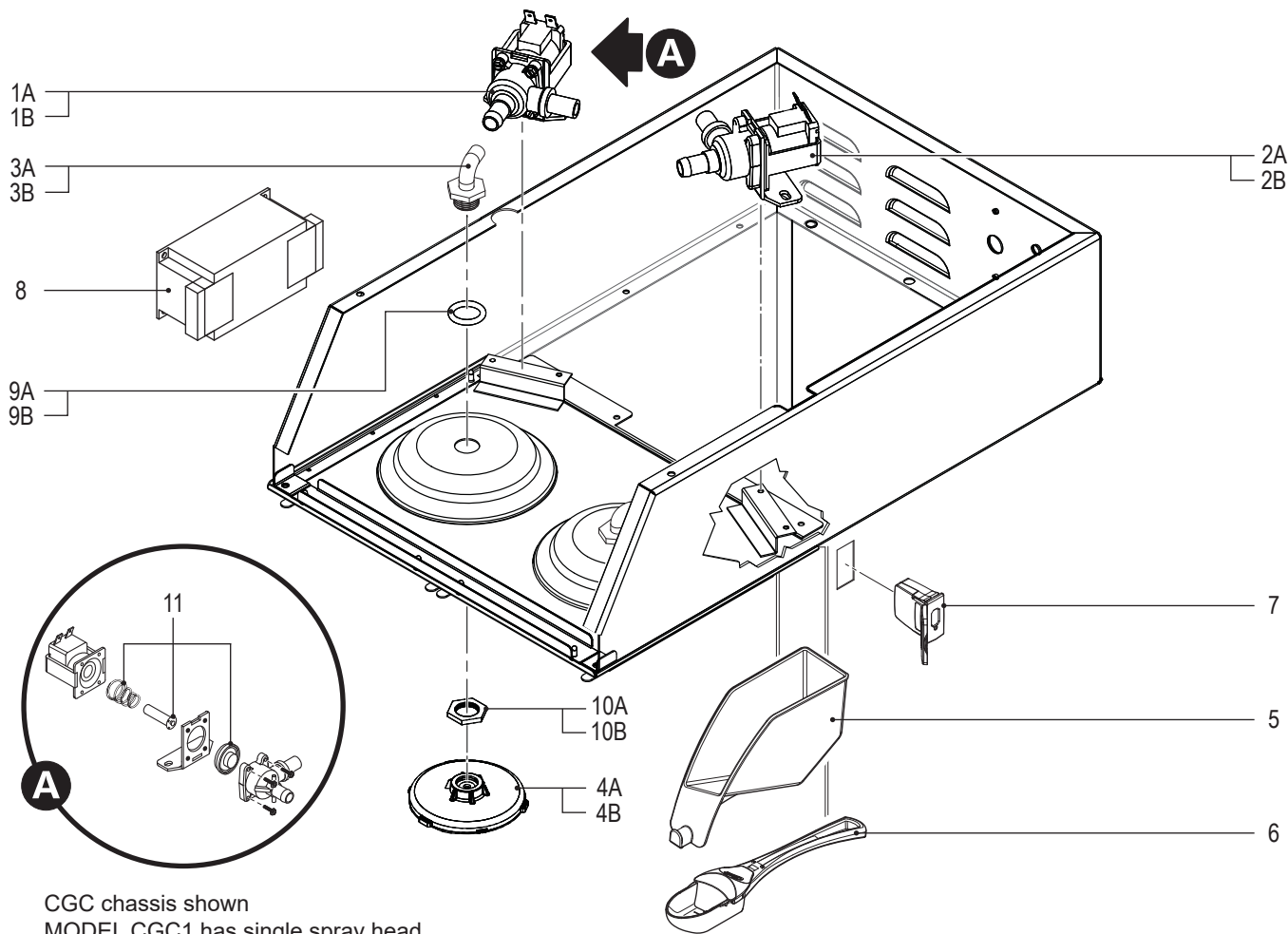

CGC chassis shown
MODEL CGC1 has single spray head

Parts List

ITEM #	PART #	DESCRIPTION
1A ^{a,b,d}	WC-889*	VALVE, DUMP LEFT 120V 12W
1B ^c	WC-860*	VALVE, DUMP LEFT 240V 12W
2A ^{a,d}	WC-817*	VALVE, DUMP RIGHT 120V 12W
2B ^c	WC-861*	VALVE, DUMP RIGHT 240V 9W
3A ¹	WC-2962K	KIT, FITTING SPRAYHEAD SS
3B ²	WC-2962-101K	KIT, FITTING SPRAYHEAD KYNAR
4A	WC-29025*	SPRAYHEAD, PURPLE ADVANCE FLOW
4B	WC-29050*	SPRAYHEAD, GRAY ADVANCE FLOW
5	WC-66087	FILTER HOLSTER CGC

ITEM #	PART #	DESCRIPTION
6	WC-66090	SCOOP, ASSEMBLY CGC
7	WC-10008K	KIT, INSTALLATION UNIVERSAL USB
8 ^{c,d}	WC-596K	KIT, NOISE FILTER EMI 250V/30A 1PH
9A ¹	WC-4320	O'RING, 0.487I.D.x 0.693OD x0.103CS
9B ²	WC-43089	GASKET, 1.000D X .625 I.D. X .030 THK
10A ¹	WC-4213-P	NUT, 5/8 LOCK PLATED
10B ²	WC-4212-02	NUT, 5/8-18 JAM PLASTIC
11	WC-37132-101	KIT, VALVE REPAIR FOR DELTROL WC-820WDR,WC-821WDR, WC-844WDR

*Recommended parts to stock

^aCGCx, ^bCGC1x, ^cCGCEx, ^dCGC13x

¹Units built 05/15/17 and later. Stainless steel fitting kit (3A) is compatible with older units.

²Units built before 05/15/17.

WC-54324 - Tank Assembly

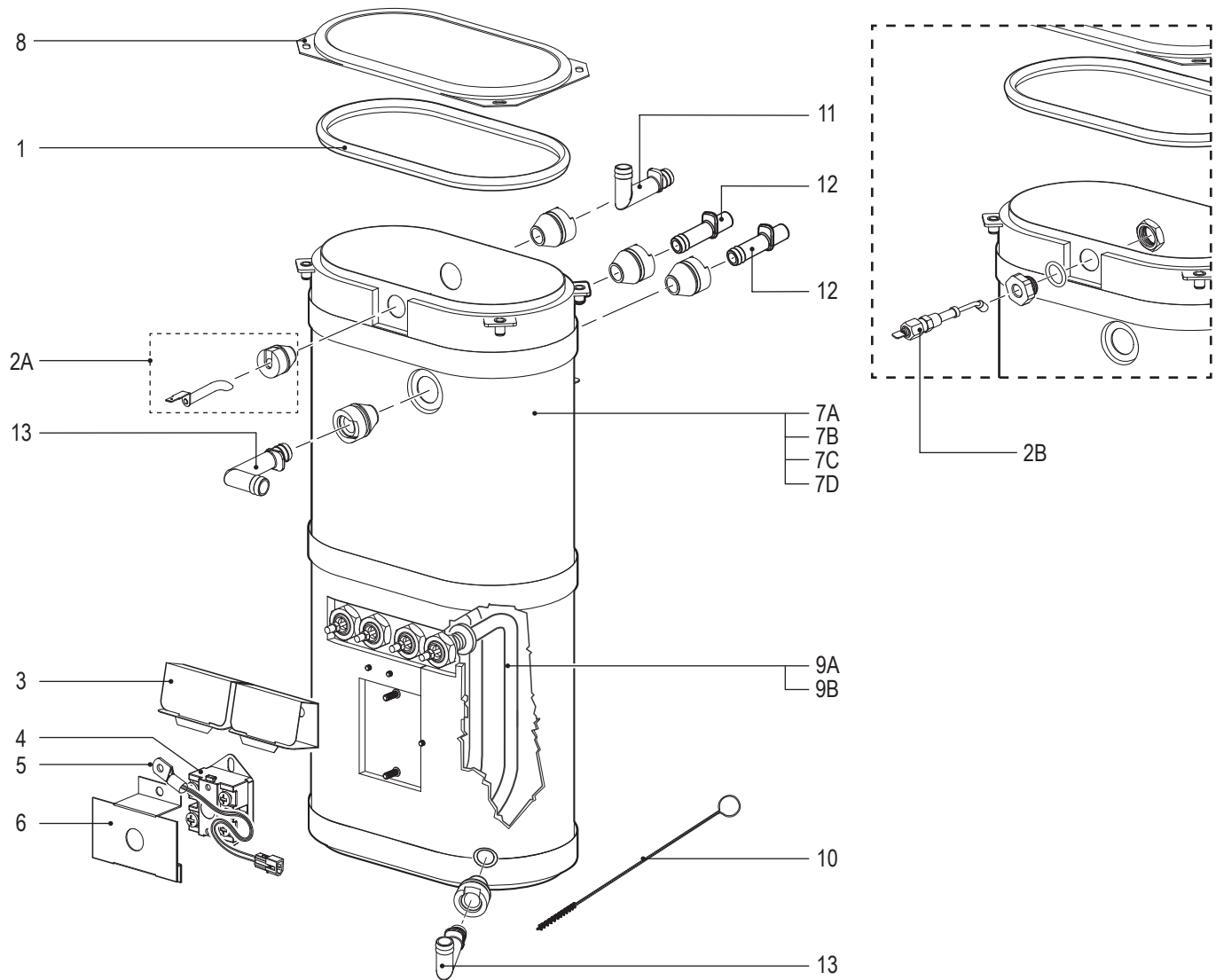

WC-54324 - Tank Assembly - Parts List

ITEM #	PART #	DESCRIPTION
1	WC-43062	GASKET, TANK LID
2A ¹	WC-5528K*	KIT, WATER LEVEL PROBE, SILICONE
2B ²	WC-5502-01*	KIT, PROBE, ASSY WATER LEVEL W/HEX FITTING, O-RING & NUT
3	WC-4394*	GUARD, SHOCK/HEATING ELEMENT FOR SINGLE HEATING ELEMENT
4	WC-522*	THERMOSTAT, HI LIMIT HEATER CONTROL DPST 277V 40A
5	WC-1438-101*	SENSOR, TEMPERATURE TANK
6	WC-43055*	GUARD, SHOCK RESET THERMOSTAT (WC-522)
7A	WC-54324DV	TANK, ASSY DUAL VOLTAGE 120/220 (2)1450W SINGLE CUP
7B	WC-54324DV-101	TANK, ASSY DUAL VOLTAGE CGC1 (2)1450W 120V
7C	WC-54324-30	TANK, ASSY CGCE (2)1600W SINGLE CUP
7D	WC-54324-130	TANK, ASSY CGC1E (2)1600W 120V

ITEM #	PART #	DESCRIPTION
8	WC-5853-102	COVER, TOP HEATING TANK GEN USE
9A ^a	WC-917-04*	ELEMENT, HEATING 1.45KW 120V W/JAM NUTS & SILICONE O-RING
9B ^b	WC-904-04*	KIT, ELEMENT, HEATING 1.6KW120V W/ JAM NUT & SILICONE O-RING
10	WC-36077*	BRUSH, 3/32" SPIRAL NYLON WC-3411/ CGC
11	WC-37266*	KIT, FITTING TANK OVERFLOW
12 ^{**}	WC-37317*	KIT, STRAIGHT FITTING & BUSHING 8mm GEN USE
13	WC-37365*	KIT, FITTING TANK INLET

* Recommended parts to stock.

** Two used on CGC and CGCE. One used on CGC1.

¹ Units built 01/04/2019 and later.

² Units built before 01/04/2019. Replaces WC-5527.

^a Domestic

^b Export

CGC - Tank Assembly, Japan

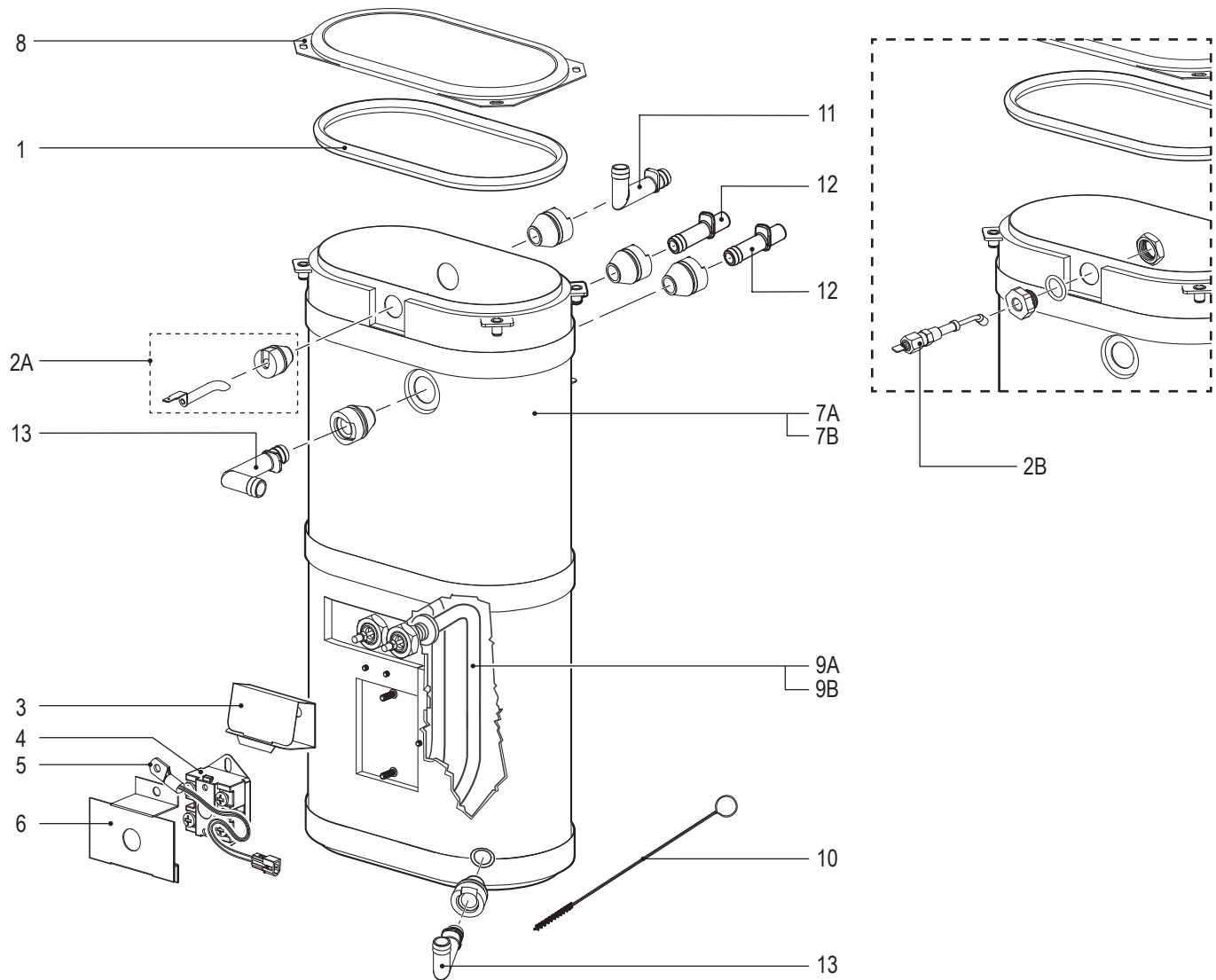

Tank Assembly - Parts List

ITEM #	PART #	DESCRIPTION
1	WC-43062*	GASKET, TANK LID
2A ¹	WC-5528K*	KIT, WATER LEVEL PROBE, SILICONE
2B ²	WC-5502-01*	KIT, PROBE, ASSY WATER LEVEL W/HEX FITTING, O-RING & NUT
3	WC-4394*	GUARD, SHOCK/HEATING ELEMENT FOR SINGLE HEATING ELEMENT
4	WC-522*	THERMOSTAT, HI LIMIT HEATER CONTROL DPST 277V 40A
5	WC-1438-101*	SENSOR, TEMPERATURE TANK
6	WC-43055*	GUARD, SHOCK RESET THERMOSTAT (WC-522)

ITEM #	PART #	DESCRIPTION
7A ^a	WC-62076	TANK, COMPLETE CGC13
7B ^b	WC-62077	TANK, COMPLETE CGC33
8	WC-5853-102	COVER, TOP HEATING TANK GEN USE
9A ^a	WC-904-04*	KIT,ELEMENT, HEATING 1.6KW120V W/ JAM NUT & SILICONE O-RING
9B ^b	WC-977*	ELEMENT, HEATING 3.6KW 200V W/JAM NUTS & SILICONE O-RING
10	WC-36077*	BRUSH, 3/32" SPIRAL NYLON WC-3411/ CGC
11	WC-37266*	KIT, FITTING TANK OVERFLOW
12	WC-37317*	KIT, STRAIGHT FITTING & BUSHNG 8mm GEN USE
13	WC-37365*	KIT, FITTING TANK INLET

^a 100 Volt units

^b 200 Volts units

¹ Units built 01/04/2019 and later.

² Units built before 01/04/2019. Replaces WC-5527.

* Recommended parts to stock.

WC-54340-30 - Tank Assembly

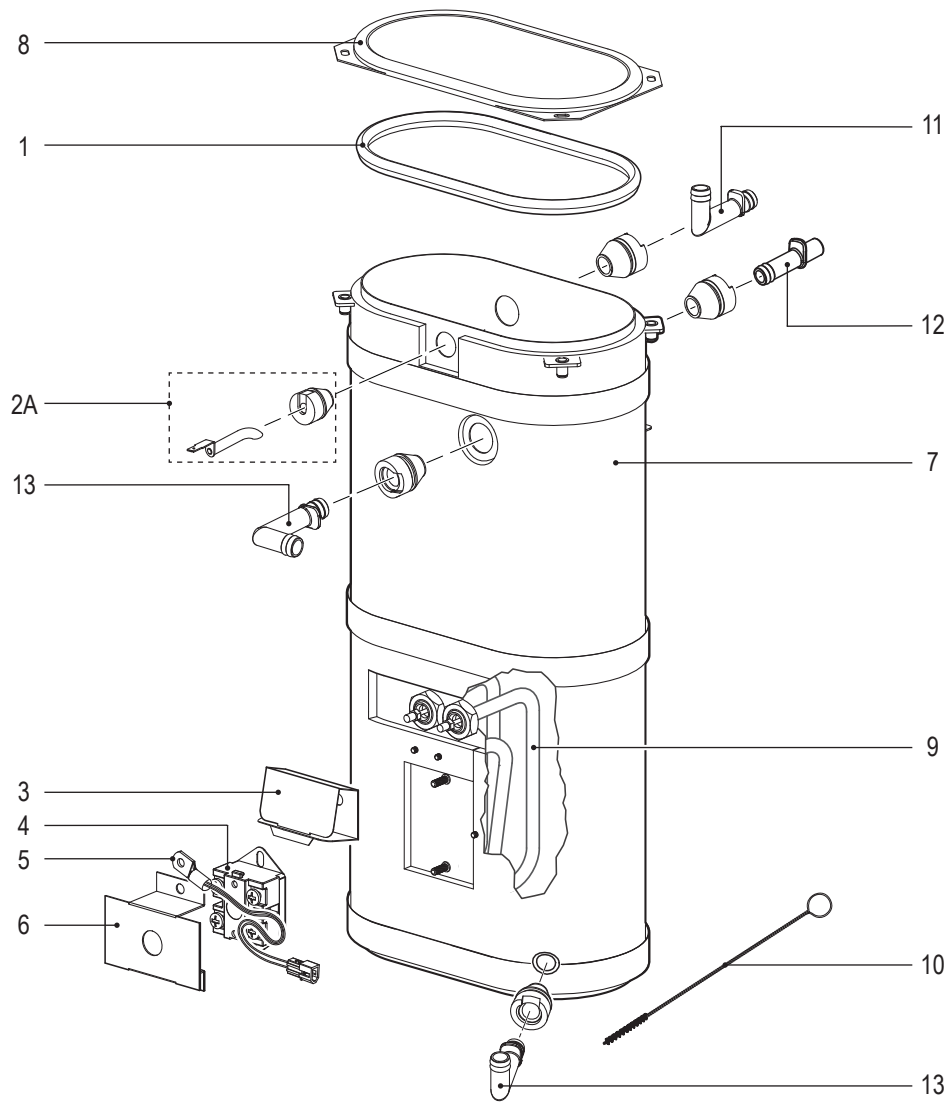

WC-54340-30 - Tank Assembly - Parts List

ITEM #	PART #	DESCRIPTION
1	WC-43062*	GASKET, TANK LID
2	WC-5528K*	KIT, WATER LEVEL PROBE, SILICONE
3	WC-4394*	GUARD, SHOCK/HEATING ELEMENT FOR SINGLE HEATING ELEMENT
4	WC-522*	THERMOSTAT, HI LIMIT HEATER CONTROL DPST 277V 40A
5	WC-1438-101*	SENSOR, TEMPERATURE TANK
6	WC-43055*	GUARD, SHOCK RESET THERMOSTAT (WC-522)
7	WC-54340-30	TANK, ASSY 230V EXPORT UNITS

ITEM #	PART #	DESCRIPTION
8	WC-5853-102	COVER, TOP HEATING TANK GEN USE
9	WC-934-04*	KIT, ELEMENT HEATING 2.5KW 220V W/JAM NUT & SILICONE WASHERS
10	WC-36077*	BRUSH, 3/32" SPIRAL NYLON WC-3411/ CGC
11	WC-37266*	KIT, FITTING TANK OVERFLOW
12 #	WC-37317*	KIT, STRAIGHT FITTING & BUSHING 8mm GEN USE
13	WC-37365*	KIT, FITTING TANK INLET

Two used on CGCE. One used on CGC1E.

* Recommended parts to stock.

CGC, CGC1

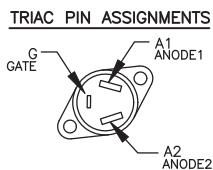
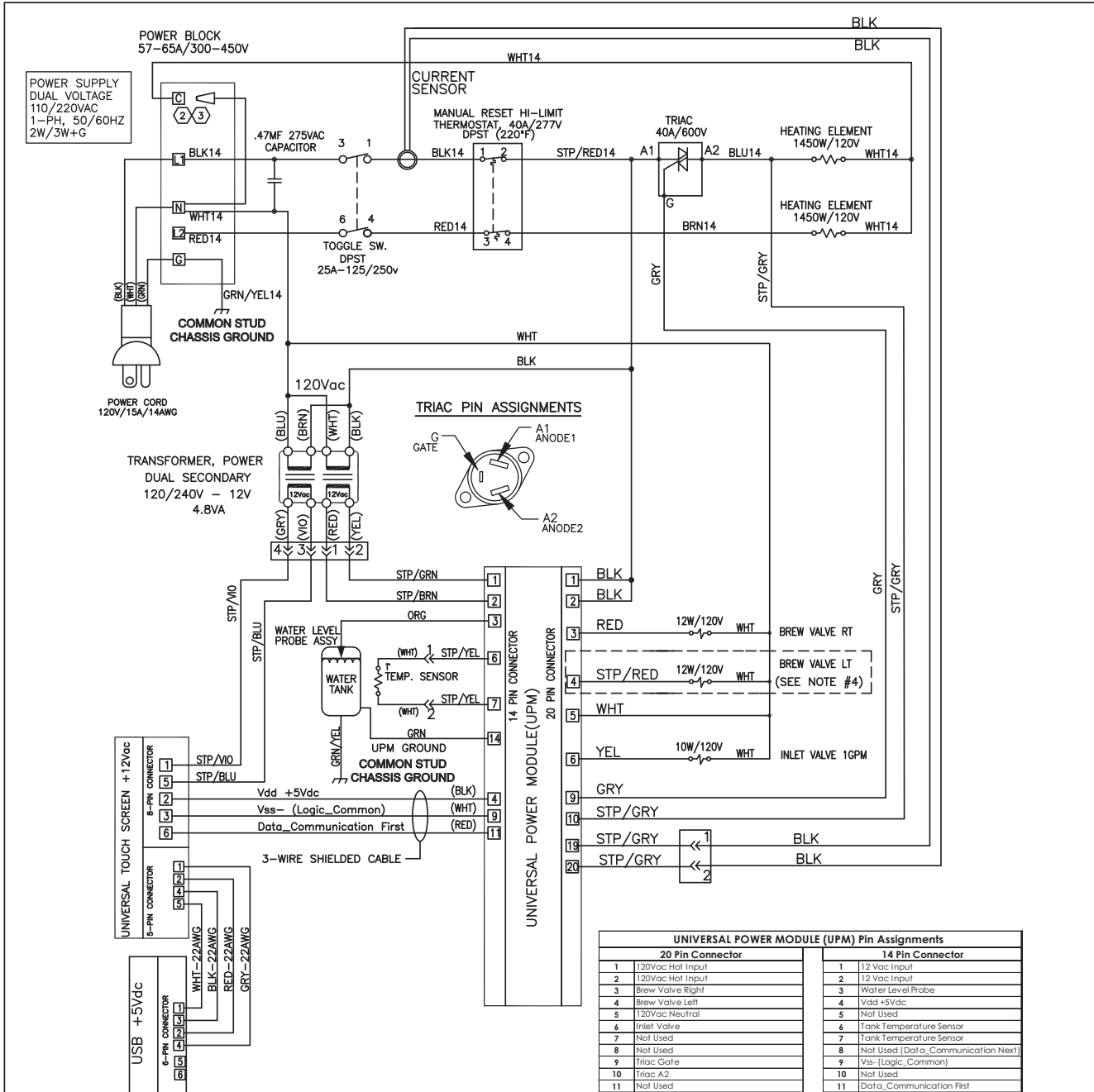

UNIVERSAL POWER MODULE (UPM) Pin Assignments	
20 Pin Connector	
1	120Vac Hot Input
2	120Vac Hot Input
3	Brew Valve Right
4	Brew Valve Left
5	120Vac Neutral
6	Inlet Valve
7	Not Used
8	Not Used
9	Triac Gate
10	Triac A2
11	Not Used
12	Not Used
13	Not Used
14	Not Used
15	Not Used
16	Not Used
17	120Vac Neutral (Internal to UPM Only)
18	Not Used
19	Current Sensor
20	Current Sensor
14 Pin Connector	
1	12 Vac Input
2	12 Vac Input
3	Water Level Probe
4	Vdd +5Vdc
5	Not Used
6	Tank Temperature Sensor
7	Tank Temperature Sensor
8	Not Used (Data_Communication Next)
9	Vs- (Logic_Common)
10	Not Used
11	Data_Communication First
12	Not Used
13	Not Used
14	UPM Ground

ELECTRICAL RATING TABLE								
Model	Voltage V	Amps A	Watts W	Hertz Hz	# of Conductor Wires	Phase	# of Tank Elements	Tank Element Rating W/V
CGCx	120	12.5	1500	50/60	(2)	1	2	1450W/120V
	110/220	10.8	2379		3			
	120	12.5	1500		(2)			
	120/240	11.6	2772		3			
CGC1x	120	12.5	1500	50/60	(2)	1	2	1450W/120V
	110/220	10.8	2379		3			
	120	12.5	1500		(2)			
	120/240	11.6	2772		3			

4. VALVE NOT USED ON MODEL: CGC1.
 ③ FOR 220V USAGE: REMOVE JUMPER FROM POINT "C" TO POINT "N" ON TERMINAL BLOCK & CAP IT.
 ② FOR 120V USAGE: CONNECT POINT "C" TO POINT "N" ON TERMINAL BLOCK (FACTORY DEFAULT)
 1. ALL WIRES SHALL BE MINIMUM 18 AWG UNLESS NOTED.
 NOTES: UNLESS OTHERWISE SPECIFIED

UNIVERSAL TOUCH SCREEN (UCM) Pin Assignments	
8 Pin Connector	
1	12 Vac Input (Back Light)
2	Vdd +5Vdc
3	Vs- (Logic_Common)
4	Not Used
5	12 Vac Input (Back Light)
6	Data_Communication First
7	Not Used
8	Not Used
5 Pin Connector	
1	TX - Transmit
2	RX - Receive
3	Not Used
4	Vdd +5Vdc
5	Vs- (Logic_Common)
USB Pin Assignments	
6-Pin Connector	
1	Vs- (Logic_Common)
2	TX - Transmit
3	Vdd +5Vdc
4	RX - Receive
5	Not Used
6	Not Used

VOLTAGE: SEE TABLE	TITLE: LADDER DIAGRAM
WATTAGE: SEE TABLE	PART NUMBER: LD-CGC
AMPERAGE: SEE TABLE	REVISION: K
HERTZ: SEE TABLE	
WIRES: 2W/3W+G	
PHASE: 1PH	

CGC13x, CGC113x

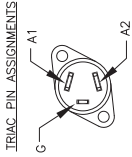
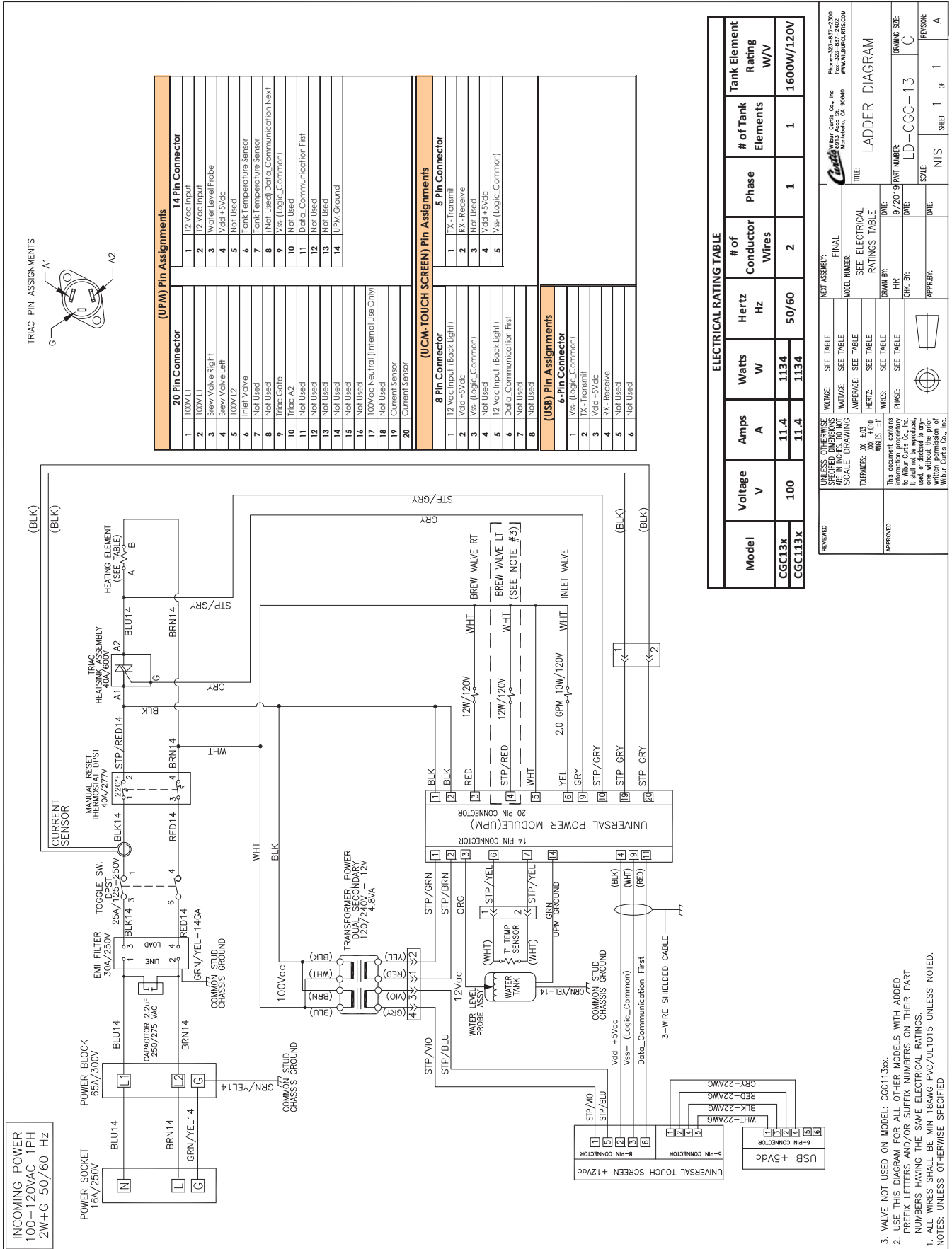

20 Pin Connector		14 Pin Connector	
1	100V L1	1	12 Vac Input
2	100V L1	2	12 Vac Input
3	Brew Valve Right	3	Water Level Probe
4	Brew Valve Left	4	Vdd +5Vdc
5	100V L2	5	Not Used
6	Inlet Valve	6	Tank Temperature Sensor
7	Not Used	7	Tank Temperature Sensor
8	Not Used	8	[Not Used] Data, Communication Next
9	Trace Gnd	9	Vss- (Logic, Common)
10	Trace A2	10	Not Used
11	Not Used	11	Data, Communication Fst
12	Not Used	12	Not Used
13	Not Used	13	Not Used
14	Not Used	14	UPM Ground
15	Not Used		
16	Not Used		
17	100 Vac Neutral (Internal Use Only)		
18	Not Used		
19	Current Sensor		
20	Current Sensor		

8 Pin Connector		5 Pin Connector	
1	12 Vac Input (Back Light)	1	TX - Terminal
2	Vdd +5Vdc	2	RX - Receive
3	Vss (Logic, Common)	3	Not Used
4	Not Used	4	Vdd +5Vdc
5	12 Vac Input (Back Light)	5	Vss (Logic, Common)
6	Data, Communication Fst		
7	Not Used		
8	Not Used		

(USB) Pin Assignments		6 Pin Connector	
1	Vss (Logic, Common)	1	TX - Terminal
2	TX - Terminal	2	RX - Receive
3	Vdd +5Vdc	3	Not Used
4	RX - Receive	4	Not Used
5	Not Used	5	Not Used
6	Not Used	6	Not Used

ELECTRICAL RATING TABLE							
Model	Voltage V	Amps A	Watts W	Hertz Hz	# of Conductor Wires	Phase	Tank Element Rating w/V
CGC13x	100	11.4	1134	50/60	2	1	1600W/120V
CGC113x		11.4	1134				

UNLESS OTHERWISE SPECIFIED DIMENSIONS ARE IN INCHES. DO NOT SCALE DRAWING	UNLESS OTHERWISE SPECIFIED DIMENSIONS ARE IN INCHES. DO NOT SCALE DRAWING	UNLESS OTHERWISE SPECIFIED DIMENSIONS ARE IN INCHES. DO NOT SCALE DRAWING	UNLESS OTHERWISE SPECIFIED DIMENSIONS ARE IN INCHES. DO NOT SCALE DRAWING	UNLESS OTHERWISE SPECIFIED DIMENSIONS ARE IN INCHES. DO NOT SCALE DRAWING	UNLESS OTHERWISE SPECIFIED DIMENSIONS ARE IN INCHES. DO NOT SCALE DRAWING	UNLESS OTHERWISE SPECIFIED DIMENSIONS ARE IN INCHES. DO NOT SCALE DRAWING	UNLESS OTHERWISE SPECIFIED DIMENSIONS ARE IN INCHES. DO NOT SCALE DRAWING
REVIEWED	APPROVED	DATE:	DATE:	DATE:	DATE:	DATE:	DATE:
NEXT ASSEMBLY	FINAL MODEL NUMBER	SEE ELECTRICAL RATINGS TABLE	SEE ELECTRICAL RATINGS TABLE	SEE ELECTRICAL RATINGS TABLE	SEE ELECTRICAL RATINGS TABLE	SEE ELECTRICAL RATINGS TABLE	SEE ELECTRICAL RATINGS TABLE
TITLE: LADDER DIAGRAM	MODEL NUMBER: LD-CGC-13	DATE: 9/2019	DATE: 9/2019	DATE: 9/2019	DATE: 9/2019	DATE: 9/2019	DATE: 9/2019
SCALE: NTS	SHEET 1 of 1	DRAWING SIZE: C	REVISION: A				

1. ALL WIRES SHALL BE MIN #8AWG PVC/UL1015 UNLESS NOTED. NOTES, UNLESS OTHERWISE SPECIFIED
2. USE THIS DIAGRAM FOR ALL OTHER MODELS WITH ADDED PREFIX LETTERS AND/OR SUFFIX NUMBERS ON THEIR PART NUMBERS HAVING THE SAME ELECTRICAL RATINGS.
3. VALVE NOT USED ON MODEL: CGC113x.

CGCE, CGC1E - Single Element Water Tank (newer units)

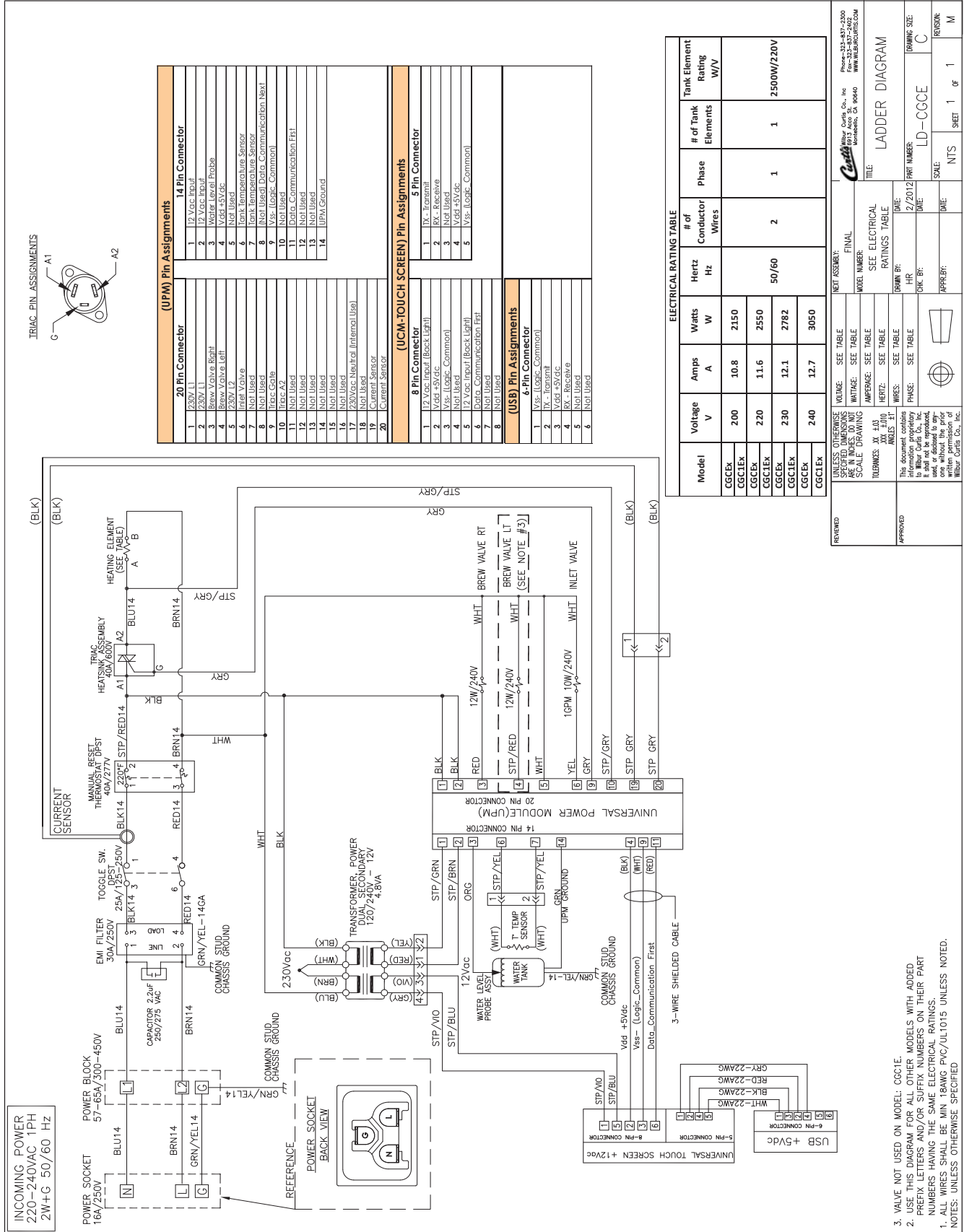

CGCE, CGC1E - Dual Element Water Tank (older units)

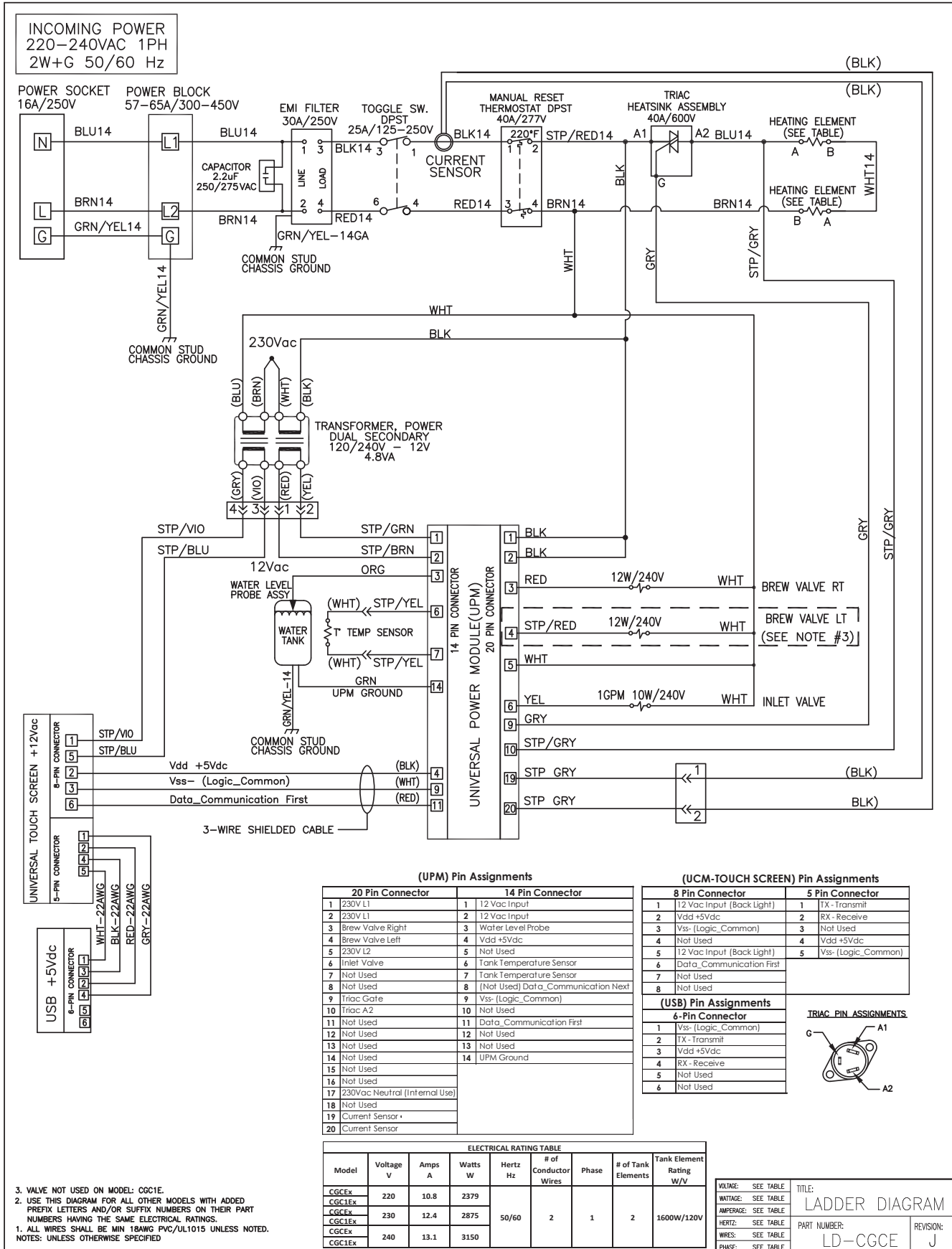

**WARNING:**

Electric Shock Hazard - the following procedures are to be performed only by a qualified service technician. Turn off power when replacing components. Neither Wilbur Curtis Co., Inc. nor the seller can be held responsible for the interpretation of this information, or any liability in connection with its use.

Scald and Burn Hazard - keep body parts clear of hot surfaces during troubleshooting.



IMPORTANT: If it is necessary to replace the G4 universal power module (UPM), always check all inlet, dump (brew), bypass* and dilution* valve coils for a short and replace the valve as necessary, before replacing the module. See the **Valve Test Procedure**, below to test for defective valves. *Some units do not have this function, see the ELECTRICAL SCHEMATIC.

Troubleshooting Guidelines

- If an error message appears on the display, consult the ERROR CODES section before troubleshooting.
- A brewer that is not level may not function properly. Make sure the brewer is properly leveled before proceeding.
- This troubleshooting guide identifies some, but not all, of the possible causes for common problems that can occur.
- Use this troubleshooting guide along with the appropriate ELECTRICAL SCHEMATIC.

Valve Test Procedure

Use a digital multi-meter to measure the resistance of valve coils.

Measure the resistance across the valve coil terminals with the wiring harness disconnected. Reverse the meter leads on the terminals and measure the resistance in the opposite direction. A resistance of less than 100 ohms, in either direction, indicates a shorted coil. The valve must be replaced.

If a shorted coil is not detected, test for an open coil:

- 1 Reconnect the valve terminals to the wiring harness.
- 2 Power up the brewer and test the valve using the diagnostics in section TG11.

Water Not Hot Enough

- 1 If the water heats, but is not hot enough, first check for the correct temperature setting on the control panel. Reprogram as necessary.
- 2 If the temperature setting is OK, and the actual water temperature does not match setting on the control panel, replace the temperature sensor.

Water Heats More Slowly Than Usual

- 1 Check for power across the terminals of the heating element(s). If power is being supplied, disconnect the heating element(s) and check for continuity. Replace a heating element if the resistance is too high (nominal resistance is 13 Ohms).
- 2 If there is no power to the heating element(s), check the wiring to any element that does not have the proper voltage across it. Also check for corroded connections anywhere between the power cord and the heating element(s).

Dispenser Overflows During Brewing

- 1 Check to make sure the control module (UCM) brew, bypass* and dilution* levels are set properly.
- 2 Check for a missing spray head. Replace as needed.
- 3 Make sure the dispenser is empty before starting the brew cycle. If not, empty it before brewing.

*Some units do not have this function, see the ELECTRICAL SCHEMATIC.

No Power - Display Not Lit

- 1 Make sure the circuit breaker to the circuit supplying power to the brewer is not tripped and is turned on.
- 2 On brewers with a power plug, make sure it is connected to the power receptacle.
- 3 Make sure that the main power toggle switch on the back panel is turned ON.
- 4 Verify that all wires from the power cord are properly connected inside the unit. Check to make sure the wires are not burned/overheated. Check chassis ground.
- 5 Check the low voltage input to the universal control module (UCM) from the transformer (see the ELECTRICAL SCHEMATIC). If there is power into the UCM, but the display is blank, the UCM is probably bad.
- 6 If there is no power into the UCM, trace the circuit back (using the wiring diagram) to the power cord to find out where power is lost. If there is power into the thermostat reset switch, but not out, see step 7.
- 7 If there is power into the thermostat reset switch, but not out, check to make sure that the water tank is not empty. If the tank is empty, the reset switch has probably opened up due to a low water level, go to **Water Tank Does Not Fill**. If there is water in the tank, but no power out, push in on the reset switch button to see if it restores power. If power is restored, check to make sure that the switch is not opening up at the wrong temperature (the switch should not open up at normal water temperatures). If there is still no power through the switch after pushing the button, replace the thermostat reset switch.

Brewer Does Not Start When Brew Button is Pressed

- 1 If **Brewing** appears on the display, check for faulty wiring and connections between the universal power module (UPM) and the valves.
- 2 If **Brewing** does not appear on the display, check for a faulty universal control module (UCM) or universal power module (UPM).

Sensor Error Message

This error indicates a malfunction (open circuit) in the temperature sensor system. Once the malfunction is corrected, the error message must be cleared. To reset the brewer and return to normal operation, turn the toggle switch on the back of the brewer to the OFF position for 5 seconds, then back ON.

- 1 Check the resistance across the leads of the temperature sensor while it is disconnected from the universal power module (UPM). If an open circuit is measured (resistance above 200 k), replace the sensor.
- 2 If the sensor resistance is less than 200 k check the sensor wires for corrosion and reconnect them to the UPM. Afterward, if the error message comes back after resetting the control and power modules, replace the UPM.

Water Tank Overfills

- 1 Turn the toggle switch on the back of the brewer ON and OFF. If water continues to flow when the switch is in both positions, replace the inlet valve.
- 2 If water stop flowing to the water tank when the toggle switch is turned OFF and continues when the switch is turned back ON, remove the orange wire from the water probe on the tank. While power is ON, short the end of the orange wire to the metal surface on the outside of the tank. If the water tank stops filling when the orange wire is shorted to the tank, check for a corroded connection at the water probe.
- 3 If water does not stop flowing when the orange wire is shorted to the tank, check the tank ground connection and the continuity of the orange wire connecting to the universal power module (UPM). If both are OK, replace the UPM.

Water Tank Does Not Fill



IMPORTANT: No water or low water in the tank can cause the tank to overheat, resulting in the thermostat reset switch opening. If after correcting a tank fill problem there is no power to the control panel, push the reset switch button to reset.

- 1 Check to make sure the water supply is turned on. Check for a plugged water supply line or plugged inlet valve.
- 2 If there are no plugs in the water supply line, check for power across the inlet valve terminals. If power is being supplied, but there is no water flow, replace the inlet valve.
- 3 If power is not being supplied to the inlet valve, check the wires between the universal power module (UPM) and the inlet valve. Check for corroded connections.
- 4 If the wiring between the UPM and the inlet valve is OK, but there is no power to the inlet valve, remove the orange wire from the water tank probe. If the water tank starts to fill, replace the water probe. If the water tank does not start to fill, replace the UPM.

Coffee/Tea Too Strong

See *Dispenser Not Filled To Normal Level During Brewing*.

Dispenser Not Filled To Normal Level During Brewing

- 1 Check to make sure that the universal control module (UCM) brew, bypass* and dilution* levels are set properly.
- 2 Check to make sure that the flow rate and water pressure from the water supply line meet the minimum specifications for the brewer. See the SPECIFICATIONS section.
- 3 Check to make sure that the spray head is clean and free of debris. Clean or replace as needed. Also make sure that the spray head is correctly aligned and that the tubing is routed properly to allow for maximum water flow (no kinks).
- 4 Remove the brew basket and place a large container under the dump (brew) and dilution outlet points. Run a brew cycle and confirm that the dump (brew) valve, bypass* valve and dilution* valve open during the brew cycle. Check for flow through any exit point that is slow or non-existent. Not all valves open at the same time. If flow is restricted, check for obstructions in the related tubing or valve. If there are no obstructions, but flow through one particular valve is slow, it can be assumed that the particular valve is not opening all the way and should be replaced. If water does not flow at all through a particular valve during the brew cycle, check to make sure that power is being supplied to the valve in question. Replace any valve that is not opening when power is applied to the terminals. If power is not being supplied to the valve, check the wiring between the valve and the universal power module (UPM). If the wiring is OK, replace the UPM.

*Some units do not have this function, see the ELECTRICAL SCHEMATIC.

Dispenser Overflows All Of The Time

- 1 Check to see if water continues to flow from the spray head, the bypass* outlet or the dilution* spout when the toggle switch is turned OFF. Replace any valve that is stuck open.
*Some units do not have this function, see the ELECTRICAL SCHEMATIC.
- 2 If one or more of the valves mentioned in step 1 turns on when the toggle switch on the back is ON and turns off when the switch is OFF, replace the universal power module (UPM).

No Water/Tea Flows From Brewer During Brewing

- 1 Make sure that the water supply is turned on.
- 2 Check to see if the water in the tank is level with the water tank probe? If not, see *Water Tank Does Not Fill*.
- 3 If the water tank is full, the water is hot and power is on, but NO water flows during a brew cycle, the problem is usually a bad universal power module (UPM). Run a brew cycle and check for power from the UPM to the dump (brew), bypass* and dilution* valves. If there is no power output, replace the UPM.
*Some units do not have this function, see the ELECTRICAL SCHEMATIC.

Low Water Flow Warning

See *Water Level Error Message*.

Water Level Error Message

Water level fill error or overflow. This error message occurs when the inlet valve solenoid has been on too long during initial fill or tank refill, See the ERROR CODES section for the maximum times allowed. Once the malfunction is corrected, the error message must be cleared. To reset the unit and return to normal operation, turn the toggle switch on the back of the brewer to the OFF position for 5 seconds, then back ON.

- 1 Check to make sure that the flow rate from the water supply line meets the minimum flow rate specifications for the brewer. Also check the water pressure. See the SPECIFICATIONS section.
- 2 Check for blockage at the inlet valve inlet or outlet. Check for blockage in the tubing between the inlet valve and the water tank.
- 3 Check the water probe wire for an open condition or corroded connections.
- 4 If the probe connections are OK, cycle power to the unit by turning the rear toggle switch OFF, then ON. Check to see if power is applied to the inlet valve terminals. If power is applied to the terminals, but there is not water flow, replace the inlet valve.
- 5 Check for power from the universal power module (UPM) to the inlet valve. If the wiring is OK, replace the UPM.

“Internal Error 1” Message on Display

Check the wiring harness that connects from pins 4, 9 and 11 of the 14-pin connector on the universal power module (UPM) to pins 2, 3 and 6 of the 8-pin connector on the universal control module (UCM).

“Internal Error 2” Message on Display

The universal power module (UPM) and universal control module (UCM) have a mismatch in their settings. A firmware update is needed. See *PROGRAMMING GUIDE*.

Water Does Not Heat At All

- Check to see if the water level in the tank is in contact with the water level probe. If not, see *Tank Does Not Fill*. The water will not heat unless it is in contact with the probe.
- If the water heats, but is not hot enough, see *Water Not Hot Enough*.
- If **Ready to brew** appears on the display, but the water is not hot, check the resistance across the leads of the temperature sensor. If the resistance is less than 10 k and the water is not hot, replace the temperature sensor. If the sensor resistance is above 10 k when the water is cool, replace the universal power module (UPM).

If **Heating...** appears on the display, but the water is not hot, follow the steps below. The following steps are performed with the rear toggle switch in the ON position.

- 1 Check for power across the terminals of the heating element(s). If power is being supplied, remove the wires and check for an open heating element.
- 2 If there is no power to the element(s), trace the circuit back (using the ELECTRICAL SCHEMATIC) to the power cord to find out where power is lost. If there is power into the triac but not out, see the following step.
- 3 If there is power into a triac, but not out, check for power at the gate terminal. Also check the wire to A2 from the UPM. If the connections are good and power is being supplied to the triac, but there is no voltage out of A2, replace the triac. If power is not being supplied from the UPM, but **Heating...** appears on the display, check the wiring from the UPM to the triac. If the wiring is OK, replace the UPM.

Water Too Hot (Boiling or Excessive Steaming)



IMPORTANT: Before proceeding, make sure that the control panel temperature is adjusted to compensate for higher elevations. The factory setting is 200 °F (92 °C). Reduce the temperature setting two degrees for every 1000 ft. (300 m) of elevation above 4000 ft. (1200 m).

- 1 If **Over Temp Sensor** or **Ready to Brew** appears on the display and the water is too hot, go to *Over Temp Sensor Error Message*.
- 2 If the display reads **Heating** constantly, first check to make sure that the temperature sensor is attached tightly to the tank and that heat sink compound was used. A properly mounted sensor should have a resistance of around 7 k when the water is hot. If not, replace the sensor.
- 3 Check to see if the universal power module (UPM) constantly has power output to the triac, regardless of the resistance of the temperature sensor. If so, the UPM is probably bad.
- 4 If the UPM is working properly, check for a shorted triac.

Over Temp Sensor Error Message

This error message indicates that the universal control module (UCM) has detected a water overheating problem. The universal power module (UPM) is reading a water temperature in the tank above 210°F. If the water temperature is too hot, but **Heating...** appears on the display, see *Water Too Hot*. Once the malfunction causing the error is corrected, the error message must be cleared. To reset the brewer and return to normal operation, turn the toggle switch on the back of the brewer to the OFF position for 5 seconds, then back on.

- 1 Check for power at the gate terminal on the triac. If there is no power at the triac gate terminal but the heating elements are always on, replace the triac.
- 2 Turn off power to the brewer and allow water tank to cool. Once cool, turn power back on while monitoring the triac gate voltage. During normal operation, power should be applied to the gate terminal, then drop to below 1 Vac. The universal power module (UPM) should be replaced if power is applied to the triac gate constantly even though **Ready to brew** or **Over Temp Sensor** appears on the display.
- 3 If the UPM is operating normally, check for a false over-temp error caused by the temperature sensor. Check the resistance across the leads of the temperature sensor. If the resistance is less than 10 k when the water is cool, replace the temperature sensor.

Overview

The G4 control module diagnostics can be used to detect electrical circuit failures in the brewer. When a circuit failure is identified, the individual components and wiring in the circuit must be checked to determine the exact cause of the failure using the ELECTRICAL SCHEMATIC. If a failure is not detected using the diagnostics, troubleshoot the problem according to the symptoms listed in other sections of this TROUBLESHOOTING GUIDE.

The diagnostics can also be used to help diagnose certain mechanical failures. See the following steps.

Using the Diagnostics

- 1 Enter programming mode by tapping the (white) Curtis logo on the touchscreen five (5) times.
- 2 Enter the access code, then press **OK** (the default code is 1 2 3 4).
- 3 The **MAIN MENU** screen will appear. Press **Control Settings**.
- 4 Press **Diagnostics**. When prompted, place an empty container under the brew basket, then press **OK**.
- 5 Press a button to test the desired circuit or **Auto Test** to test all circuits. If a button is highlighted green the circuit has passed the (electrical) test. If the button is highlighted red, the circuit has failed the test.

If the circuit tested fails, check to make sure that power is being supplied to the component during normal operation. If power is supplied, and it does not operate, replace the component. If power is not being supplied, check the wiring and the UPM.

If a valve circuit passes the test, check for a mechanical failure by listening for the valve to “click” when the test button is pressed. To check for a failed pump, run a brew cycle and check for fluid flow through the pump.

Display view varies with model



Curtis logo

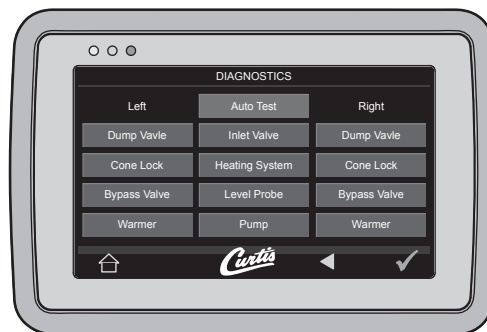

Diagnostics Screen

Button layout varies based on model

Warning Messages - Allows Brewer to Continue Brewing

MESSAGE DISPLAY	WARNING DESCRIPTION	CAUSE
Maintenance Required	Maintenance Required	Brew count "Gallons Since Reset" exceeds programmed preventative maintenance period.
Low Water Flow Warning	Low Water Flow	If the Inlet valve remains on longer than XX seconds (during the brew cycle only) and repeats TWICE during that brew cycle. It shall clear upon the next brew and if the same low flow exists again, it will re-appear. XX = Alpha 20 secs; Gem/TP Twin 40 secs; Gem/TP Single 30 secs.
Internal Error 2	UPM-UCM have a mismatch in their settings.	UPM-UCM have a mismatch in their settings, firmware update needed.

Error Messages - Brewer Will Stop Brewing

MESSAGE DISPLAY	ERROR DESCRIPTION	CAUSE
Water Level Error	Fill run error/Overflow	The water inlet valve has either been open for more than 10 minutes on the initial tank fill or has been open for 120 seconds on large brewers and 30 seconds on CGC, Seraphim® tea, or combo brewers in normal operation.
Sensor Error	Open Sensor	Break in the temperature thermistor circuit or short circuit.
Over Temp. Error*	Excess Temperature	The sensor is reading that the temperature in the heating tank has risen above 210°F, or the sensor has shorted to ground.
Internal Error 1	UPM-UCM Communication	Break in the UPM-UCM communication circuit.

* This error is disabled on CGC and Seraphim® models.

Configuration Error Message - Brewer Will Not Function Properly

MESSAGE DISPLAY	ERROR DESCRIPTION	CAUSE
Configuration Error	UPM software revision does not support the model selected.	The universal power module (UPM) has an old software version and is not compatible with the brewer model in which it has been installed.

Wilbur Curtis Co., Inc. certifies that its products are free from defects in material and workmanship under normal use. The following limited warranties and conditions apply:

- 3 years, parts and labor, from original date of purchase on digital control boards
- 2 years, parts, from original date of purchase on all other electrical components, fittings and tubing
- 1 year, labor, from original date of purchase on all other electrical components, fittings and tubing

Additionally, Wilbur Curtis Co., Inc. warrants its grinding burrs for four (4) years from the date of purchase. Stainless steel components are warranted for two (2) years from the date of purchase against leaking or pitting. Replacement parts are warranted for ninety (90) days from the date of purchase or for the remainder of the limited warranty period of the equipment in which the component is installed.

All in-warranty service calls must have prior authorization. For authorization, call the Technical Support Department at 800-995-0417. Additional conditions may apply. Go to www.wilburcurtis.com to view the full product warranty information.

CONDITIONS & EXCEPTIONS

The warranty covers original equipment at time of purchase only. Wilbur Curtis Co., Inc., assumes no responsibility for substitute replacement parts installed on Curtis equipment that have not been purchased from Wilbur Curtis Co., Inc. Wilbur Curtis Co., Inc. will not accept any responsibility if the following conditions are not met. The warranty does not cover:

- **Adjustments and cleaning:** *The resetting of safety thermostats and circuit breakers, programming and temperature adjustments are the responsibility of the equipment owner. The owner is responsible for proper cleaning and regular maintenance of this equipment.*
- **Replacement of items subject to normal use and wear:** *This shall include, but is not limited to, spray heads, faucets, light bulbs, shear disks, "O" rings, gaskets, silicone tubing, silicone elbows, canister assemblies, whipper chambers and plates, mixing bowls, agitation assemblies and whipper propellers.*

The warranty is void under the following circumstances:

- **Improper operation of equipment:** *The equipment must be used for its designed and intended purpose and function.*
- **Improper installation of equipment:** *This equipment must be installed by a professional technician and must comply with all local electrical, mechanical and plumbing codes.*
- **Improper voltage:** *Equipment must be installed at the voltage stated on the serial plate supplied with this equipment.*
- **Improper water supply:** *This includes, but is not limited to, excessive or low water pressure and inadequate or fluctuating water flow rate.*
- **Damaged in transit:** *Equipment damaged in transit is the responsibility of the freight company and a claim should be made with the carrier.*
- **Abuse or neglect (including failure to periodically clean or remove lime accumulations):** *The manufacturer is not responsible for variation in equipment operation due to excessive lime or local water conditions. The equipment must be maintained according to the manufacturer's recommendations.*
- **Unauthorized repair or modification:** *This equipment must be serviced only by qualified service technicians, using factory specified parts to factory specifications.*
- **Modified/Missing Serial Tag:** *The serial number label (tag) must not be defaced or removed.*

Repairs and/or Replacements are subject to Curtis' decision that the workmanship or parts were faulty and the defects showed up under normal use. All labor shall be performed during regular working hours. Overtime charges are the responsibility of the owner. Charges incurred by delays, waiting time, or operating restrictions that hinder the service technician's ability to perform service is the responsibility of the owner of the equipment. This includes institutional and correctional facilities. Wilbur Curtis Co., Inc. will allow up to 100 miles, round trip, per in-warranty service call.

Return Merchandise Authorization (RMA): All claims under this warranty must be submitted to the Wilbur Curtis Technical Support Department prior to performing any repair work or return of this equipment to the factory. **All returned equipment must be properly re-packaged in the original carton and received by Curtis within 45 days following the issuance of a RMA.** No units will be accepted if they are damaged in transit due to improper packaging. **NO UNITS OR PARTS WILL BE ACCEPTED WITHOUT A RETURN MERCHANDISE AUTHORIZATION (RMA). THE RMA NUMBER MUST BE MARKED ON THE CARTON OR SHIPPING LABEL. All warranty claims must be submitted within 60 days of service. Invoices will not be processed or accepted without a RMA number. Any defective parts must be returned in order for warranty invoices to be processed and approved.** All in-warranty service calls must be performed by an authorized service agent. Call the Wilbur Curtis Technical Support Department to find an agent near you.